



# High-Performance, Single-Ended, Current-Mode PWM Controllers

## General Description

The MAX5094A/B/C/D/MAX5095A/B/C BiCMOS, high-performance, current-mode PWM controllers have all the features required for wide input-voltage range isolated/nonisolated power supplies. These controllers are used for low- and high-power universal input voltage and telecom power supplies.

The MAX5094/MAX5095 contain a fast comparator with only 60ns typical delay from current sense to the output for overcurrent protection. The MAX5094 has an integrated error amplifier with the output at COMP. Soft-start is achieved by controlling the COMP voltage rise using external components.

The oscillator frequency is adjustable from 20kHz to 1MHz with an external resistor and capacitor. The timing capacitor discharge current is trimmed allowing for programmable dead time and maximum duty cycle for a given frequency. The available saw-toothed waveform at R<sub>T</sub>C<sub>T</sub> can be used for slope compensation when needed.

The MAX5095A/MAX5095B include a bidirectional synchronization circuit allowing for multiple controllers to run at the same frequency to avoid beat frequencies. Synchronization is accomplished by simply connecting the SYNC of all devices together. When synchronizing with other devices, the MAX5095A/MAX5095B with the highest frequency synchronizes the other devices. Alternatively, the MAX5095A/MAX5095B can be synchronized to an external clock with an open-drain output stage running at a higher frequency.

The MAX5095C provides a clock output pulse (ADV\_CLK) that leads the driver output (OUT) by 110ns. The advanced clock signal is used to drive the secondary-side synchronous rectifiers.

The MAX5094A/B/C are available in the 8-pin SO and 8-pin  $\mu$ MAX<sup>®</sup> packages. The MAX5094D and MAX5095A/B/C are available in the 8-pin  $\mu$ MAX package. All devices operate over the automotive temperature range of -40°C to +125°C.

## Applications

- Universal Input AC/DC Power Supplies
- Isolated Telecom Power Supplies
- Isolated Power-Supply Modules
- Networking Systems
- Computer Systems/Servers
- Industrial Power Conversion
- Isolated Keep-Alive Circuits

$\mu$ MAX is a registered trademark of Maxim Integrated Products, Inc.



## Features

- ◆ Pin-for-Pin Replacement for UCC28C43 (MAX5094A) and UCC28C45 (MAX5094B)
- ◆ 2A Drive Source and 1A Sink Capability
- ◆ Up to 1MHz Switching Frequency Operation
- ◆ Bidirectional Frequency Synchronization (MAX5095A/MAX5095B)
- ◆ Advanced Output Drive for Secondary-Side Synchronous Rectification (MAX5095C)
- ◆ Fast 60ns Cycle-by-Cycle Current Limit
- ◆ Trimmed Oscillator Capacitor Discharge Current Sets Maximum Duty Cycle Accurately
- ◆ Accurate  $\pm 5\%$  Start Voltage with 0.8V Hysteresis
- ◆ Low 32 $\mu$ A Startup Current
- ◆ 5V Regulator Output (REF) with 20mA Capability
- ◆ Versions with 0.3V Current-Sense Threshold
- ◆ Overtemperature Shutdown

## Ordering Information

PART	TEMP RANGE	PIN-PACKAGE	PKG CODE
MAX5094AASA	-40°C to +125°C	8 SO	S8-4
MAX5094AASA+	-40°C to +125°C	8 SO	S8-4
MAX5094AAUA*	-40°C to +125°C	8 $\mu$ MAX	U8-1
MAX5094AAUA+	-40°C to +125°C	8 $\mu$ MAX	U8-1
MAX5094BASA*	-40°C to +125°C	8 SO	S8-4
MAX5094BASA+	-40°C to +125°C	8 SO	S8-4
MAX5094BAUA*	-40°C to +125°C	8 $\mu$ MAX	U8-1
MAX5094BAUA+	-40°C to +125°C	8 $\mu$ MAX	U8-1

+Denotes lead-free package.

\*Future product—contact factory for availability.

Ordering Information continued at end of data sheet.

## Pin Configurations

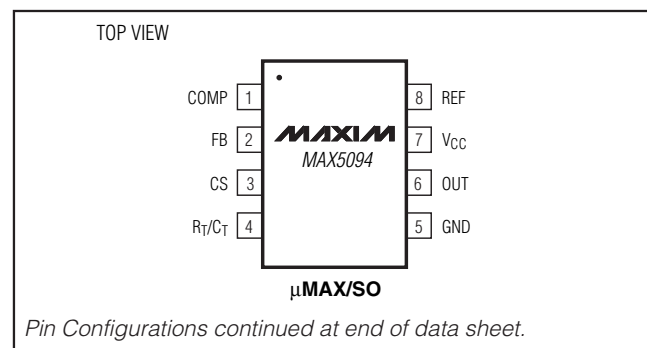

MAX5094A/B/C/D/MAX5095A/B/C

# High-Performance, Single-Ended, Current-Mode PWM Controllers

## ABSOLUTE MAXIMUM RATINGS

V<sub>CC</sub> (Low-Impedance Source) to GND .....-0.3V to +30V  
 V<sub>CC</sub> (I<sub>CC</sub> < 30mA).....Self Limiting  
 OUT to GND .....-0.3V to (V<sub>CC</sub> + 0.3V)  
 OUT Current.....±1A for 10μs  
 FB, SYNC, COMP, CS, R<sub>T</sub>/C<sub>T</sub>, REF to GND .....-0.3V to +6V  
 COMP Sink Current (MAX5094).....10mA

Continuous Power Dissipation (T<sub>A</sub> = +70°C)  
 8-Pin μMAX (derate 4.5mW/°C above +70°C) .....362mW  
 8-Pin SO (derate 5.9mW/°C above +70°C).....470.6mW  
 Operating Temperature Range .....-40°C to +125°C  
 Maximum Junction Temperature .....+150°C  
 Storage Temperature Range .....-65°C to +150°C  
 Lead Temperature (soldering, 10s).....+300°C

Stresses beyond those listed under "Absolute Maximum Ratings" may cause permanent damage to the device. These are stress ratings only, and functional operation of the device at these or any other conditions beyond those indicated in the operational sections of the specifications is not implied. Exposure to absolute maximum rating conditions for extended periods may affect device reliability.

## ELECTRICAL CHARACTERISTICS

(V<sub>CC</sub> = +15V, R<sub>T</sub> = 10kΩ, C<sub>T</sub> = 3.3nF, REF = open, C<sub>REF</sub> = 0.1μF, COMP = open, V<sub>FB</sub> = 2V, CS = GND, T<sub>A</sub> = T<sub>J</sub> = -40°C to +85°C, unless otherwise noted.) (Note 1)

PARAMETER	SYMBOL	CONDITIONS	MIN	TYP	MAX	UNITS
<b>REFERENCE</b>						
Output Voltage	V <sub>REF</sub>	T <sub>A</sub> = +25°C, I <sub>REF</sub> = 1mA	4.950	5.000	5.050	V
Line Regulation	ΔV <sub>LINE</sub>	12V ≤ V <sub>CC</sub> ≤ 25V, I <sub>REF</sub> = 1mA		0.4	4	mV
Load Regulation	ΔV <sub>LOAD</sub>	1mA ≤ I <sub>REF</sub> ≤ 20mA		6	25	mV
Total Output Variation	V <sub>REFT</sub>	1mA ≤ I <sub>REF</sub> ≤ 20mA, 12V ≤ V <sub>CC</sub> ≤ 25V	4.9		5.1	V
Reference Output-Noise Voltage	V <sub>NOISE</sub>	10Hz ≤ f ≤ 10kHz, T <sub>A</sub> = +25°C		50		μV
Reference Output Short Circuit	I <sub>S_SC</sub>	V <sub>REF</sub> = 0V	-30	-100	-180	mA
<b>OSCILLATOR</b>						
Initial Accuracy		T <sub>A</sub> = +25°C	51	54	57	kHz
Voltage Stability		12V ≤ V <sub>CC</sub> ≤ 25V		0.2	0.5	%
Temp Stability		-40°C ≤ T <sub>A</sub> ≤ +85°C		0.5		%
R <sub>T</sub> /C <sub>T</sub> Voltage Ramp (P-P)	V <sub>RAMP</sub>			1.7		V
R <sub>T</sub> /C <sub>T</sub> Voltage Ramp Valley	V <sub>RAMP_VALLEY</sub>			1.1		V
Discharge Current	I <sub>DIS</sub>	V <sub>RT/CT</sub> = 2V, T <sub>A</sub> = +25°C	7.9	8.3	8.7	mA
		V <sub>RT/CT</sub> = 2V, -40°C ≤ T <sub>A</sub> ≤ +85°C	7.5	8.3	9.0	
Frequency Range	f <sub>OSC</sub>		20		1000	kHz
<b>ERROR AMPLIFIER (MAX5094)</b>						
FB Input Voltage	V <sub>FB</sub>	FB shorted to COMP	2.465	2.5	2.535	V
FB Input Bias Current	I <sub>B(FB)</sub>			-0.01	-0.1	μA
Open-Loop Voltage Gain	A <sub>VOL</sub>	2V ≤ V <sub>COMP</sub> ≤ 4V		100		dB
Unity-Gain Bandwidth	f <sub>GBW</sub>			1		MHz
Power-Supply Rejection Ratio	PSRR	12V ≤ V <sub>CC</sub> ≤ 25V (Note 2)	60	80		dB
COMP Sink Current	I <sub>SINK</sub>	V <sub>FB</sub> = 2.7V, V <sub>COMP</sub> = 1.1V	2	6		mA
COMP Source Current	I <sub>SOURCE</sub>	V <sub>FB</sub> = 2.3V, V <sub>COMP</sub> = 5V	-0.5	-1.2	-1.8	mA
COMP Output High Voltage	V <sub>COMP_H</sub>	V <sub>FB</sub> = 2.3V, R <sub>COMP</sub> = 15kΩ to GND	5	5.8		V
COMP Output Low Voltage	V <sub>COMP_L</sub>	V <sub>FB</sub> = 2.7V, R <sub>COMP</sub> = 15kΩ to REF		0.1	1.1	V
<b>CURRENT-SENSE AMPLIFIER</b>						
Gain (Notes 3, 4)	A <sub>CS</sub>	(MAX5094A/MAX5094B)	2.85	3	3.26	V/V
		(MAX5094C/D, MAX5095_)	2.85	3	3.40	V/V

# High-Performance, Single-Ended, Current-Mode PWM Controllers

MAX5094A/B/C/D/MAX5095A/B/C

## ELECTRICAL CHARACTERISTICS (continued)

( $V_{CC} = +15V$ ,  $R_T = 10k\Omega$ ,  $C_T = 3.3nF$ , REF = open,  $C_{REF} = 0.1\mu F$ , COMP = open,  $V_{FB} = 2V$ , CS = GND,  $T_A = T_J = -40^\circ C$  to  $+85^\circ C$ , unless otherwise noted.) (Note 1)

PARAMETER	SYMBOL	CONDITIONS	MIN	TYP	MAX	UNITS
Maximum Current-Sense Signal	VCS_MAX	MAX5094A/B (Note 3)	0.95	1	1.05	V
		MAX5094C/MAX5094D (Note 3)	0.275	0.3	0.325	
		$V_{COMP} = 5V$ , MAX5095	0.275	0.3	0.325	
Power-Supply Rejection Ratio	PSRR	$12V \leq V_{CC} \leq 25V$		70		dB
Input Bias Current	I <sub>CS</sub>	$V_{COMP} = 0V$		-1	-2.5	$\mu A$
Delay From CS to OUT	t <sub>CS_DELAY</sub>	50mV overdrive		60		ns
<b>MOSFET DRIVER</b>						
OUT Low-Side On-Resistance	V <sub>RDS_ONL</sub>	I <sub>SINK</sub> = 200mA		4.5	10	$\Omega$
OUT High-Side On-Resistance	V <sub>RDS_ONH</sub>	I <sub>SOURCE</sub> = 100mA		3.5	7	$\Omega$
I <sub>SOURCE</sub> (Peak)	I <sub>SOURCE</sub>	C <sub>OUT</sub> = 10nF		2		A
I <sub>SINK</sub> (Peak)	I <sub>SINK</sub>	C <sub>OUT</sub> = 10nF		1		A
Rise Time	t <sub>R</sub>	C <sub>OUT</sub> = 1nF		15		ns
Fall Time	t <sub>F</sub>	C <sub>OUT</sub> = 1nF		22		ns
<b>UNDERVOLTAGE LOCKOUT/STARTUP</b>						
Startup Voltage Threshold	V <sub>CC_START</sub>		7.98	8.40	8.82	V
Minimum Operating Voltage After Turn-On	V <sub>CC_MIN</sub>		7.1	7.6	8.0	V
Undervoltage-Lockout Hysteresis	UVLO <sub>HYST</sub>			0.8		V
<b>PWM</b>						
Maximum Duty Cycle	D <sub>MAX</sub>	MAX5094A/MAX5094C/MAX5095A	94.5	96	97.5	%
		MAX5094B/MAX5094D/MAX5095B/MAX5095C	48	49.8	50	
Minimum Duty Cycle	D <sub>MIN</sub>				0	%
<b>SUPPLY CURRENT</b>						
Startup Supply Current	I <sub>START</sub>	$V_{CC} = 7.5V$		32	65	$\mu A$
Operating Supply Current	I <sub>CC</sub>	$V_{FB} = V_{CS} = 0V$		3	5	mA
Zener Bias Voltage at V <sub>CC</sub>	V <sub>Z</sub>	I <sub>CC</sub> = 25mA	24	26.5		V
<b>THERMAL SHUTDOWN</b>						
Thermal Shutdown	T <sub>SHDN</sub>	Junction temperature rising		150		$^\circ C$
Thermal Shutdown Hysteresis	T <sub>HYST</sub>			4		$^\circ C$
<b>SYNCHRONIZATION (MAX5095A/MAX5095B Only) (Note 5)</b>						
SYNC Frequency Range	f <sub>SYNC</sub>		20		1000	kHz
SYNC Clock Input High Threshold	V <sub>SYNCINH</sub>		3.5			V
SYNC Clock Input Low Threshold	V <sub>SYNCINL</sub>				0.8	V
SYNC Clock Input Minimum Pulse Width	t <sub>PW_SYNCIN</sub>		200			ns
SYNC Clock Output High Level	V <sub>SYNCOH</sub>	1mA external pulldown	4.0	4.7		V
SYNC Clock Output Low Level	V <sub>SYNCOL</sub>	R <sub>SYNC</sub> = 5k $\Omega$		0	0.1	V
SYNC Leakage Current	I <sub>SYNC</sub>	$V_{SYNC} = 0V$		0.01	0.1	$\mu A$

# High-Performance, Single-Ended, Current-Mode PWM Controllers

## ELECTRICAL CHARACTERISTICS (continued)

( $V_{CC} = +15V$ ,  $R_T = 10k\Omega$ ,  $C_T = 3.3nF$ , REF = open,  $C_{REF} = 0.1\mu F$ , COMP = open,  $V_{FB} = 2V$ , CS = GND,  $T_A = T_J = -40^\circ C$  to  $+85^\circ C$ , unless otherwise noted.) (Note 1)

PARAMETER	SYMBOL	CONDITIONS	MIN	TYP	MAX	UNITS
<b>ADV_CLK (MAX5095C Only)</b>						
ADV_CLK High Voltage	$V_{ADV\_CLKH}$	$I_{ADV\_CLK} = 10mA$ source	2.4	3		V
ADV_CLK Low Voltage	$V_{ADV\_CLKL}$	$I_{ADV\_CLK} = 10mA$ sink			0.4	V
ADV_CLK Output Pulse Width	$t_{PULSE}$			85		ns
ADV_CLK Rising Edge to OUT Rising Edge	$t_{ADV\_CLK}$			110		ns
ADV_CLK Source and Sink Current	$I_{ADV\_CLK}$		10			mA

## ELECTRICAL CHARACTERISTICS

( $V_{CC} = +15V$ ,  $R_T = 10k\Omega$ ,  $C_T = 3.3nF$ , REF = open,  $C_{REF} = 0.1\mu F$ , COMP = open,  $V_{FB} = 2V$ , CS = GND,  $T_A = T_J = -40^\circ C$  to  $+125^\circ C$ , unless otherwise noted.) (Note 1)

PARAMETER	SYMBOL	CONDITIONS	MIN	TYP	MAX	UNITS
<b>REFERENCE</b>						
Output Voltage	$V_{REF}$	$T_A = +25^\circ C$ , $I_{REF} = 1mA$	4.950	5.000	5.050	V
Line Regulation	$\Delta V_{LINE}$	$12V \leq V_{CC} \leq 25V$ , $I_{REF} = 1mA$		0.4	4	mV
Load Regulation	$\Delta V_{LOAD}$	$1mA \leq I_{REF} \leq 20mA$		6	25	mV
Total Output Variation	$V_{REFT}$	$1mA \leq I_{REF} \leq 20mA$ , $12V \leq V_{CC} \leq 25V$	4.9		5.1	V
Reference Output-Noise Voltage	$V_{NOISE}$	$10Hz \leq f \leq 10kHz$ , $T_A = +25^\circ C$		50		$\mu V$
Reference Output Short Circuit	$I_{S\_SC}$	$V_{REF} = 0V$	-30	-100	-180	mA
<b>OSCILLATOR</b>						
Initial Accuracy		$T_A = +25^\circ C$	51	54	57	kHz
Voltage Stability		$12V \leq V_{CC} \leq 25V$		0.2	0.5	%
Temp Stability		$-40^\circ C \leq T_A \leq +125^\circ C$		1		%
$R_T/C_T$ Voltage Ramp (P-P)	$V_{RAMP}$			1.7		V
$R_T/C_T$ Voltage Ramp Valley	$V_{RAMP\_VALLEY}$			1.1		V
Discharge Current	$I_{DIS}$	$V_{RT/CT} = 2V$ , $T_A = +25^\circ C$	7.9	8.3	8.7	mA
		$V_{RT/CT} = 2V$ , $-40^\circ C \leq T_A \leq +125^\circ C$	7.5	8.3	9.0	
Frequency Range	$f_{OSC}$		20		1000	kHz
<b>ERROR AMPLIFIER (MAX5094)</b>						
FB Input Voltage	$V_{FB}$	FB shorted to COMP	2.465	2.5	2.535	V
FB Input Bias Current	$I_{B(FB)}$			-0.01	-0.1	$\mu A$
Open-Loop Voltage Gain	$A_{VOL}$	$2V \leq V_{COMP} \leq 4V$		100		dB
Unity-Gain Bandwidth	$f_{GBW}$			1		MHz
Power-Supply Rejection Ratio	PSRR	$12V \leq V_{CC} \leq 25V$ (Note 2)	60	80		dB
COMP Sink Current	$I_{SINK}$	$V_{FB} = 2.7V$ , $V_{COMP} = 1.1V$	2	6		mA
COMP Source Current	$I_{SOURCE}$	$V_{FB} = 2.3V$ , $V_{COMP} = 5V$	-0.5	-1.2	-1.8	mA
COMP Output High Voltage	$V_{COMPH}$	$V_{FB} = 2.3V$ , $R_{COMP} = 15k\Omega$ to GND	5	5.8		V
COMP Output Low Voltage	$V_{COMPL}$	$V_{FB} = 2.7V$ , $R_{COMP} = 15k\Omega$ to REF		0.1	1.1	V

# High-Performance, Single-Ended, Current-Mode PWM Controllers

MAX5094A/B/C/D/MAX5095A/B/C

## ELECTRICAL CHARACTERISTICS (continued)

( $V_{CC} = +15V$ ,  $R_T = 10k\Omega$ ,  $C_T = 3.3nF$ , REF = open,  $C_{REF} = 0.1\mu F$ , COMP = open,  $V_{FB} = 2V$ , CS = GND,  $T_A = T_J = -40^\circ C$  to  $+125^\circ C$ , unless otherwise noted.) (Note 1)

PARAMETER	SYMBOL	CONDITIONS	MIN	TYP	MAX	UNITS
<b>CURRENT-SENSE AMPLIFIER</b>						
Gain (Notes 3, 4)	ACS	MAX5094A/MAX5094B	2.85	3	3.26	V/V
		MAX5094C/D, MAX5095_	2.85	3	3.40	
Maximum Current-Sense Signal	VCS_MAX	MAX5094A/B (Note 3)	0.95	1	1.05	V
		MAX5094C/MAX5094D (Note 3)	0.275	0.300	0.325	
		$V_{COMP} = 5V$ , MAX5095_	0.275	0.300	0.325	
Power-Supply Rejection Ratio	PSRR	$12V \leq V_{CC} \leq 25V$		70		dB
Input Bias Current	$I_{CS}$	$V_{COMP} = 0V$		-1	-2.5	$\mu A$
Delay From CS to OUT	$t_{CS\_DELAY}$	50mV overdrive		60		ns
<b>MOSFET DRIVER</b>						
OUT Low-Side On-Resistance	$V_{RDS\_ONL}$	$I_{SINK} = 200mA$		4.5	12	$\Omega$
OUT High-Side On-Resistance	$V_{RDS\_ONH}$	$I_{SOURCE} = 100mA$		3.5	9	$\Omega$
$I_{SOURCE}$ (Peak)	$I_{SOURCE}$	$C_{OUT} = 10nF$		2		A
$I_{SINK}$ (Peak)	$I_{SINK}$	$C_{OUT} = 10nF$		1		A
Rise Time	$t_R$	$C_{OUT} = 1nF$		15		ns
Fall Time	$t_F$	$C_{OUT} = 1nF$		22		ns
<b>UNDERVOLTAGE LOCKOUT/STARTUP</b>						
Startup Voltage Threshold	$V_{CC\_START}$		7.98	8.4	8.82	V
Minimum Operating Voltage After Turn-On	$V_{CC\_MIN}$		7.1	7.6	8.0	V
Undervoltage-Lockout Hysteresis	$UVLO_{HYST}$			0.8		V
<b>PWM</b>						
Maximum Duty Cycle	$D_{MAX}$	MAX5094A/MAX5094C/MAX5095A	94.5	96	97.5	%
		MAX5094B/MAX5094D/MAX5095B/MAX5095C	48	49.8	50	
Minimum Duty Cycle	$D_{MIN}$			0		%
<b>SUPPLY CURRENT</b>						
Startup Supply Current	$I_{START}$	$V_{CC} = 7.5V$		32	65	$\mu A$
Operating Supply Current	$I_{CC}$	$V_{FB} = V_{CS} = 0V$		3	5	mA
Zener Bias Voltage at $V_{CC}$	$V_Z$	$I_{CC} = 25mA$	24	26.5		V
<b>THERMAL SHUTDOWN</b>						
Thermal Shutdown	$T_{SHDN}$	Junction temperature rising		150		$^\circ C$
Thermal Shutdown Hysteresis	$T_{HYST}$			4		$^\circ C$
<b>SYNCHRONIZATION (MAX5095A/MAX5095B Only) (Note 5)</b>						
SYNC Frequency Range	$f_{SYNC}$		20		1000	kHz
SYNC Clock Input High Threshold	$V_{SYNCINH}$		3.5			V
SYNC Clock Input-Low Threshold	$V_{SYNCINL}$				0.8	V
SYNC Clock Input Minimum Pulse Width	$t_{PW\_SYNCIN}$		200			ns

# High-Performance, Single-Ended, Current-Mode PWM Controllers

## ELECTRICAL CHARACTERISTICS (continued)

( $V_{CC} = +15V$ ,  $R_T = 10k\Omega$ ,  $C_T = 3.3nF$ , REF = open,  $C_{REF} = 0.1\mu F$ , COMP = open,  $V_{FB} = 2V$ , CS = GND,  $T_A = T_J = -40^\circ C$  to  $+125^\circ C$ , unless otherwise noted.) (Note 1)

PARAMETER	SYMBOL	CONDITIONS	MIN	TYP	MAX	UNITS
SYNC Clock Output High Level	$V_{SYNCOH}$	1mA external pulldown	4.0	4.7		V
SYNC Clock Output Low Level	$V_{SYNCOL}$	$R_{SYNC} = 5k\Omega$		0	0.1	V
SYNC Leakage Current	$I_{SYNC}$	$V_{SYNC} = 0V$		0.01	0.1	$\mu A$
<b>ADV_CLK (MAX5095C Only)</b>						
ADV_CLK High Voltage	$V_{ADV\_CLKH}$	$I_{ADV\_CLK} = 10mA$ source	2.4	3		V
ADV_CLK Low Voltage	$V_{ADV\_CLKL}$	$I_{ADV\_CLK} = 10mA$ sink			0.4	V
ADV_CLK Output Pulse Width	$t_{PULSE}$			85		ns
ADV_CLK Rising Edge to OUT Rising Edge	$t_{ADV\_CLK}$			110		ns
ADV_CLK Source and Sink Current	$I_{ADV\_CLK}$		10			mA

**Note 1:** All devices are 100% tested at  $+25^\circ C$ . All limits over temperature are guaranteed by design, not production tested.

**Note 2:** Guaranteed by design, not production tested.

**Note 3:** Parameter measured at trip point of latch with  $V_{FB} = 0$  (MAX5094 only).

**Note 4:** Gain is defined as  $A = \Delta V_{COMP} / \Delta V_{CS}$ ,  $0 \leq V_{CS} \leq 0.8V$  for MAX5094A/MAX5094B,  $0 \leq V_{CS} \leq 0.2V$  for MAX5094C/MAX5094D/ MAX5095\_.

**Note 5:** Output frequency equals oscillator frequency for MAX5094A/MAX5094C/MAX5095A. Output frequency is one-half oscillator frequency for MAX5094B/MAX5094D/MAX5095B/MAX5095C.

## Typical Operating Characteristics

( $V_{CC} = 15V$ ,  $T_A = +25^\circ C$ , unless otherwise noted.)

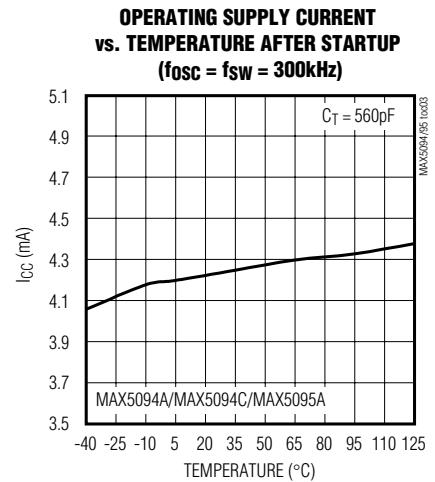
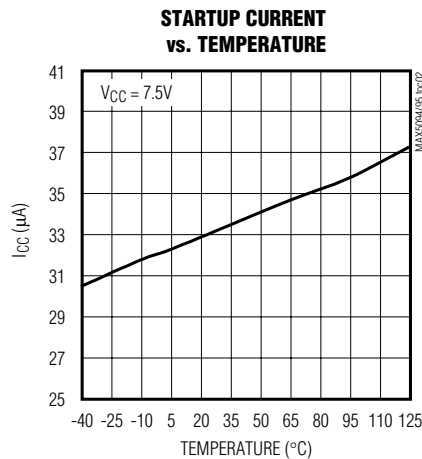
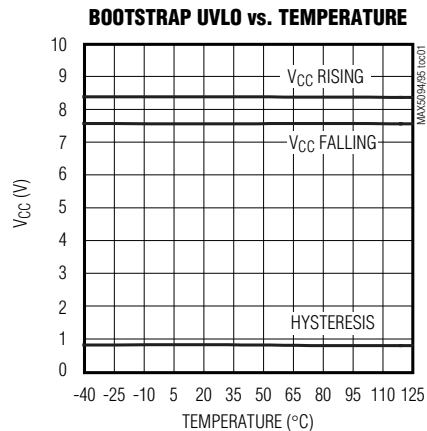

# High-Performance, Single-Ended, Current-Mode PWM Controllers

## Typical Operating Characteristics (continued)

( $V_{CC} = 15V$ ,  $T_A = +25^\circ C$ , unless otherwise noted.)

MAX5094A/B/C/D/MAX5095A/B/C

**REFERENCE VOLTAGE vs. TEMPERATURE**

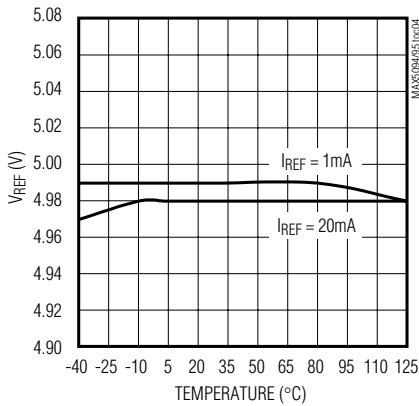

**REFERENCE VOLTAGE vs. REFERENCE LOAD CURRENT**

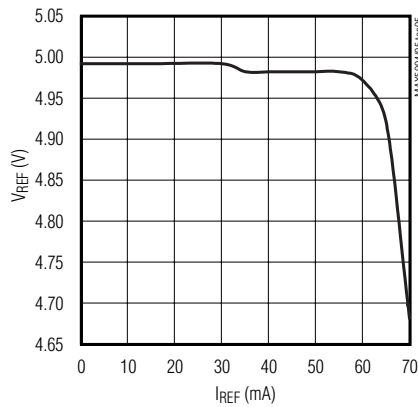

**REFERENCE VOLTAGE vs. SUPPLY VOLTAGE**

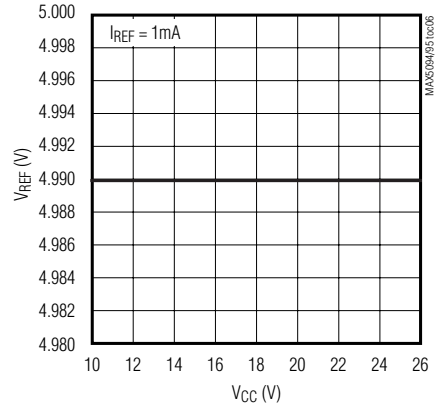

**OSCILLATOR FREQUENCY ( $f_{osc}$ ) vs. TEMPERATURE**

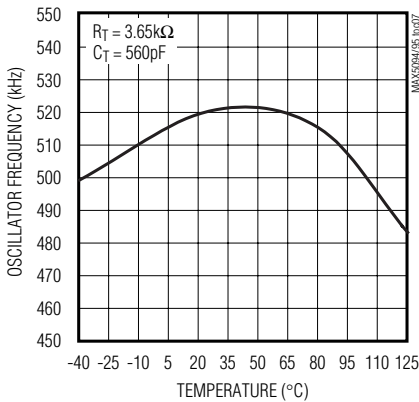

**OSCILLATOR  $R_T/C_T$  DISCHARGE CURRENT vs. TEMPERATURE**

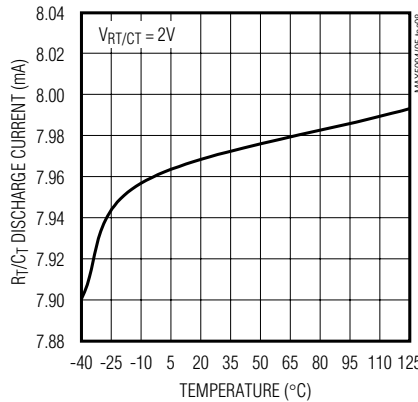

**MAXIMUM DUTY CYCLE vs. TEMPERATURE**

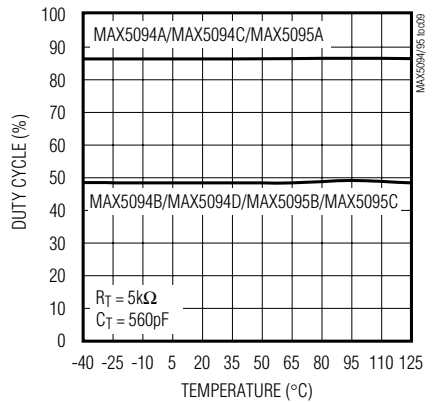

**MAXIMUM DUTY CYCLE vs. FREQUENCY  
MAX5094A/MAX5094C/MAX5095A**

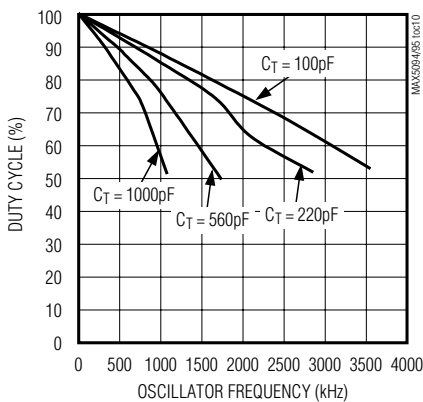

**CURRENT-SENSE TRIP THRESHOLD vs. TEMPERATURE**

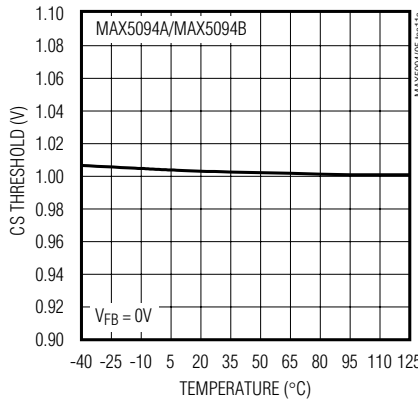

**CURRENT-SENSE TRIP THRESHOLD vs. TEMPERATURE**

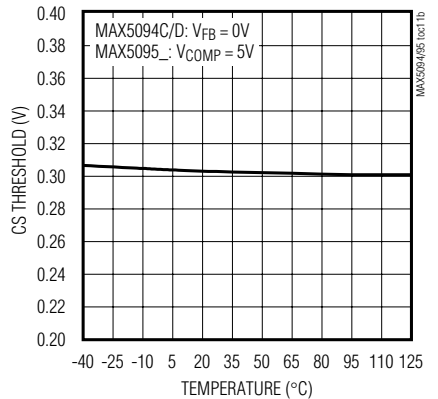

# High-Performance, Single-Ended, Current-Mode PWM Controllers

## Typical Operating Characteristics (continued)

( $V_{CC} = 15V$ ,  $T_A = +25^\circ C$ , unless otherwise noted.)

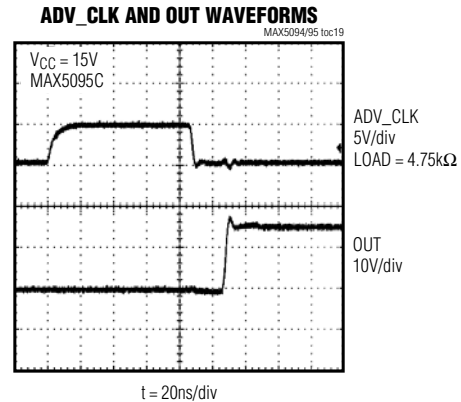
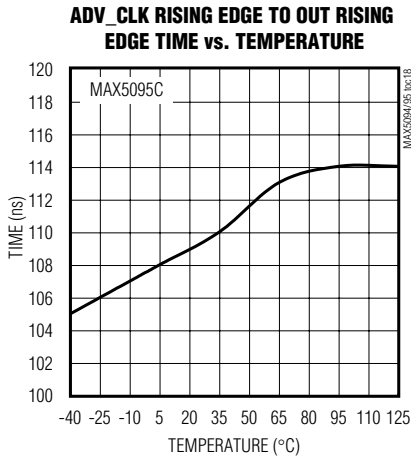
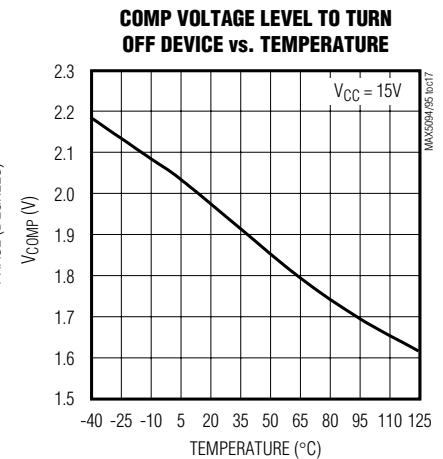
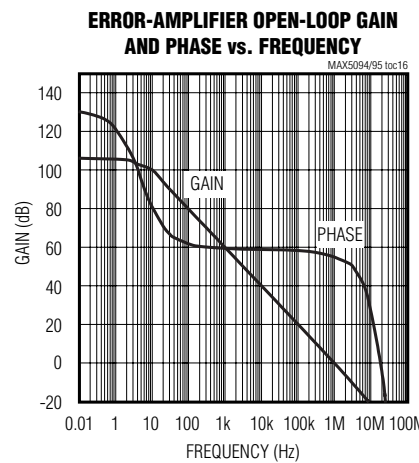
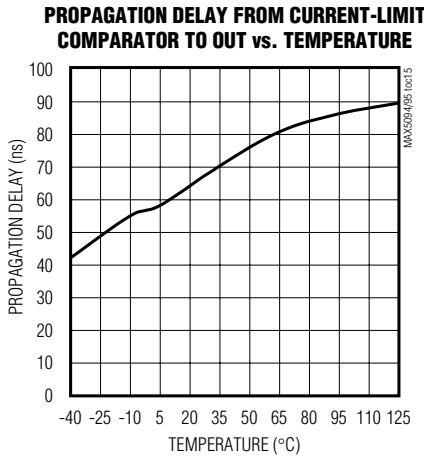
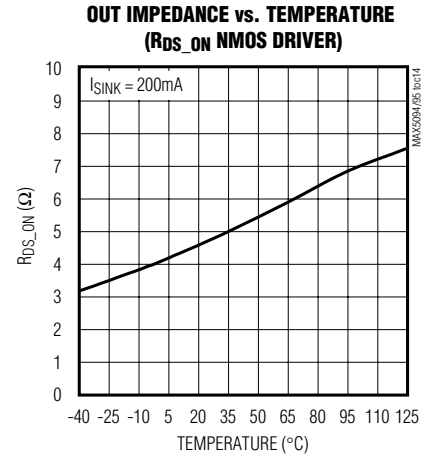
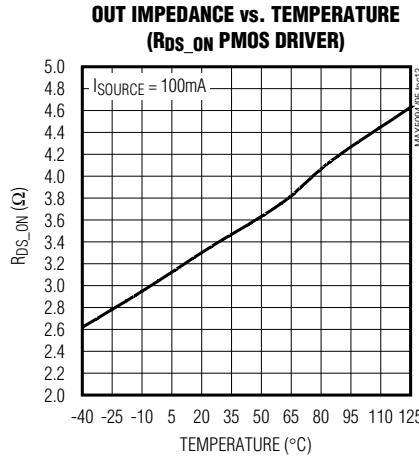
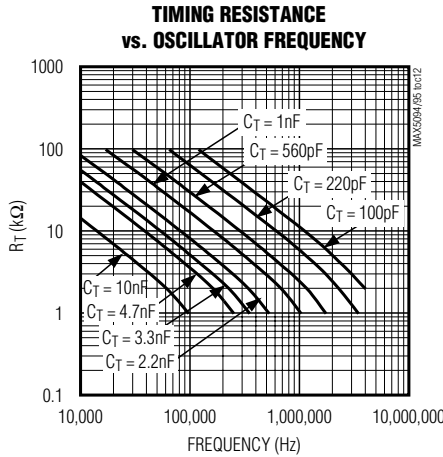



# High-Performance, Single-Ended, Current-Mode PWM Controllers

## Typical Operating Characteristics (continued)

( $V_{CC} = 15V$ ,  $T_A = +25^\circ C$ , unless otherwise noted.)

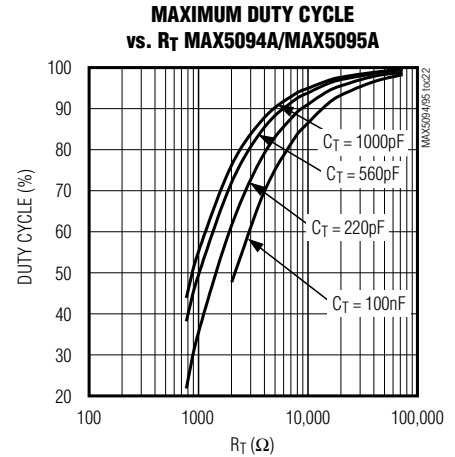
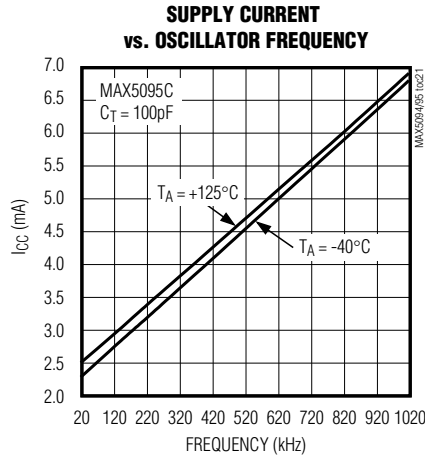
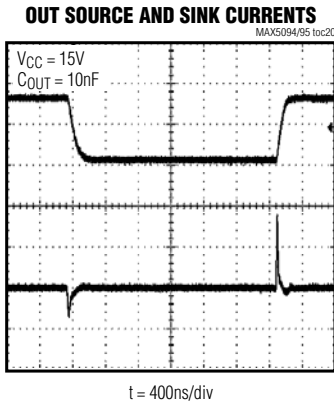

## Pin Descriptions

### MAX5094\_

PIN	NAME	FUNCTION
1	COMP	Error-Amplifier Output. COMP can be used for soft-start.
2	FB	Error-Amplifier Inverting Input
3	CS	PWM Comparator and Overcurrent Protection Comparator Input. The current-sense signal is compared to a signal proportional to the error-amplifier output voltage.
4	$R_T/C_T$	Timing Resistor/Capacitor Connection. A resistor $R_T$ from $R_T/C_T$ to REF and capacitor $C_T$ from $R_T/C_T$ to GND set the oscillator frequency.
5	GND	Power-Supply Ground. Place the $V_{CC}$ and REF bypass capacitors close to the IC to minimize ground loops.
6	OUT	MOSFET Driver Output. OUT connects to the gate of the external n-channel MOSFET.
7	$V_{CC}$	Power-Supply Input. Bypass $V_{CC}$ to GND with a 0.1 $\mu F$ ceramic capacitor or a parallel combination of a 0.1 $\mu F$ and a higher value ceramic capacitor.
8	REF	5V Reference Output. Bypass REF to GND with a 0.1 $\mu F$ ceramic capacitor or a parallel combination of a 0.1 $\mu F$ and a higher value ceramic capacitor no larger than 4.7 $\mu F$ .

MAX5094A/B/C/D/MAX5095A/B/C

# High-Performance, Single-Ended, Current-Mode PWM Controllers

## Pin Descriptions (continued)

### MAX5095\_

PIN		NAME	FUNCTION
MAX5095A/ MAX5095B	MAX5095C		
1	1	COMP	Current Limit/PWM Comparator Input. COMP is level-shifted and connected to the inverting input of the PWM comparator. Pull up COMP to REF through a resistor and connect an optocoupler from COMP to GND for proper operation.
2	—	SYNC	Bidirectional Synchronization Input. When synchronizing with other MAX5095A/MAX5095Bs, the higher frequency part synchronizes all other devices.
—	2	ADV_CLK	Advance Clock Output. ADV_CLK is an 85ns clock output pulse preceding the rising edge of OUT (see Figure 4). Use the pulse to drive the secondary-side synchronous rectifiers through a pulse transformer or an optocoupler (see Figure 8).
3	3	CS	PWM Comparator/Overcurrent Protection Comparator Input. The current-sense signal is compared to the level shifted voltage at COMP.
4	4	R <sub>T</sub> /C <sub>T</sub>	Timing Resistor/Capacitor Connection. A resistor R <sub>T</sub> from R <sub>T</sub> /C <sub>T</sub> to REF and capacitor C <sub>T</sub> from R <sub>T</sub> /C <sub>T</sub> to GND set the oscillator frequency.
5	5	GND	Power-Supply Ground. Place the V <sub>CC</sub> and REF bypass capacitors close to the IC to minimize ground loops.
6	6	OUT	MOSFET Driver Output. OUT connects to the gate of the external n-channel MOSFET.
7	7	V <sub>CC</sub>	Power-Supply Input. Bypass V <sub>CC</sub> to GND with a 0.1μF ceramic capacitor or a parallel combination of a 0.1μF and a higher value ceramic capacitor.
8	8	REF	5V Reference Output. Bypass REF to GND with a 0.1μF ceramic capacitor or a parallel combination of a 0.1μF and a higher value ceramic capacitor no larger than 4.7μF.

MAX5094A/B/C/D/MAX5095A/B/C

# High-Performance, Single-Ended, Current-Mode PWM Controllers

MAX5094A/B/C/D/MAX5095A/B/C

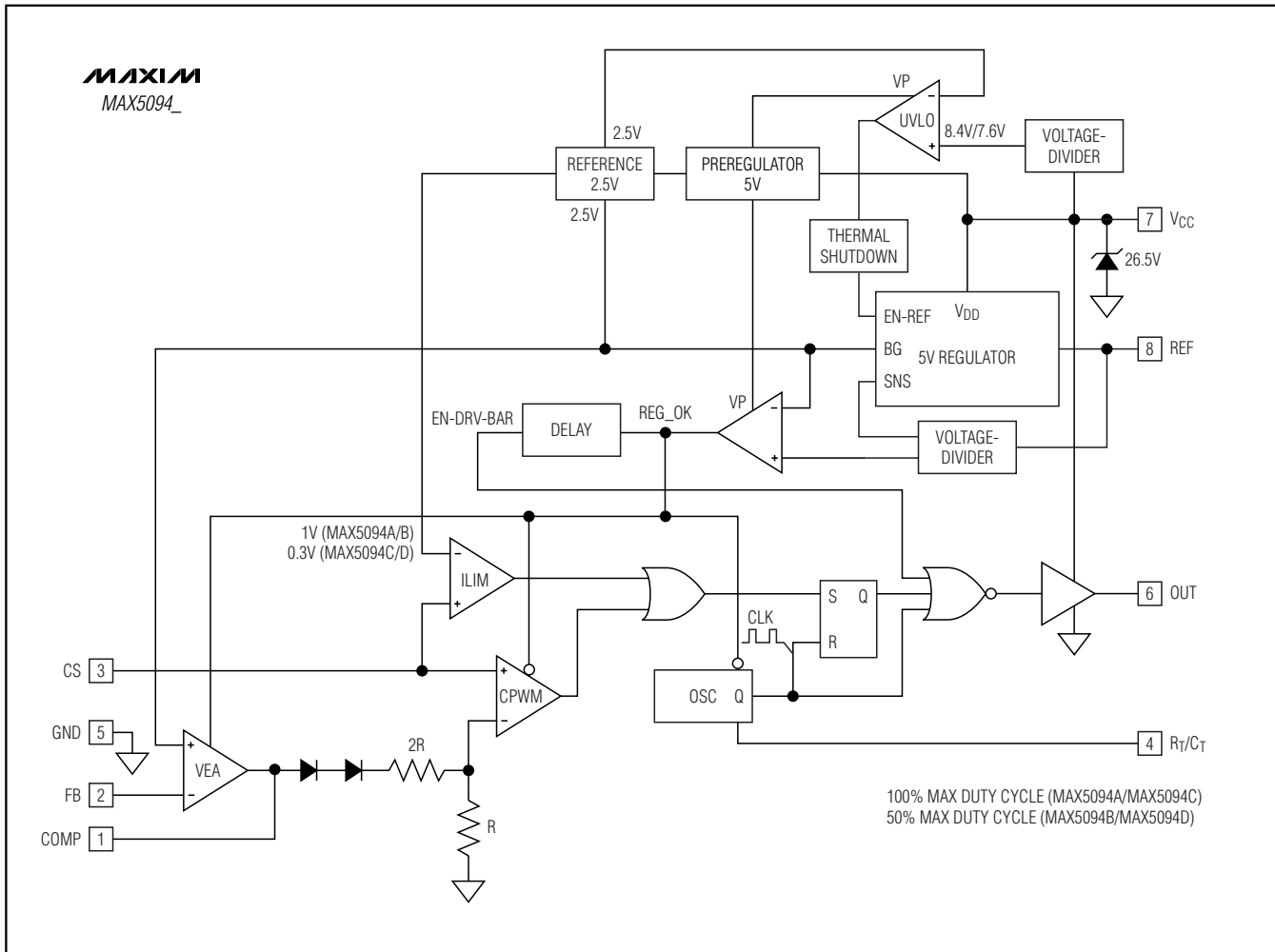

Figure 1. MAX5094\_ Functional Diagram

## Detailed Description

The MAX5094\_/MAX5095\_ current-mode PWM controllers are designed for use as the control and regulation core of flyback or forward topology switching power supplies. These devices incorporate an integrated low-side driver, adjustable oscillator, error amplifier (MAX5094\_ only), current-sense amplifier, 5V reference, and external synchronization capability (MAX5095A/MAX5095B only). An internal +26.5V current-limited VCC clamp prevents overvoltage during startup.

Eight different versions of the MAX5094/MAX5095 are available as shown in the Selector Guide. The MAX5094A/MAX5094B are the standard versions with a

feedback input (FB) and internal error amplifier. The MAX5095A/MAX5095B include bidirectional synchronization (SYNC). This enables multiple MAX5095A/MAX5095Bs to be connected and synchronized to the device with the highest frequency. The MAX5095C includes an ADV\_CLK output, which precedes the MAX5095C's drive output (OUT) by 110ns. Figures 1, 2, and 3 show the internal functional diagrams of the MAX5094\_, MAX5095A/MAX5095B, and MAX5095C, respectively. The MAX5094A/MAX5094C/MAX5095A are capable of 100% maximum duty cycle. The MAX5094B/MAX5094D/MAX5095B/MAX5095C limit the maximum duty cycle to 50%.

# High-Performance, Single-Ended, Current-Mode PWM Controllers

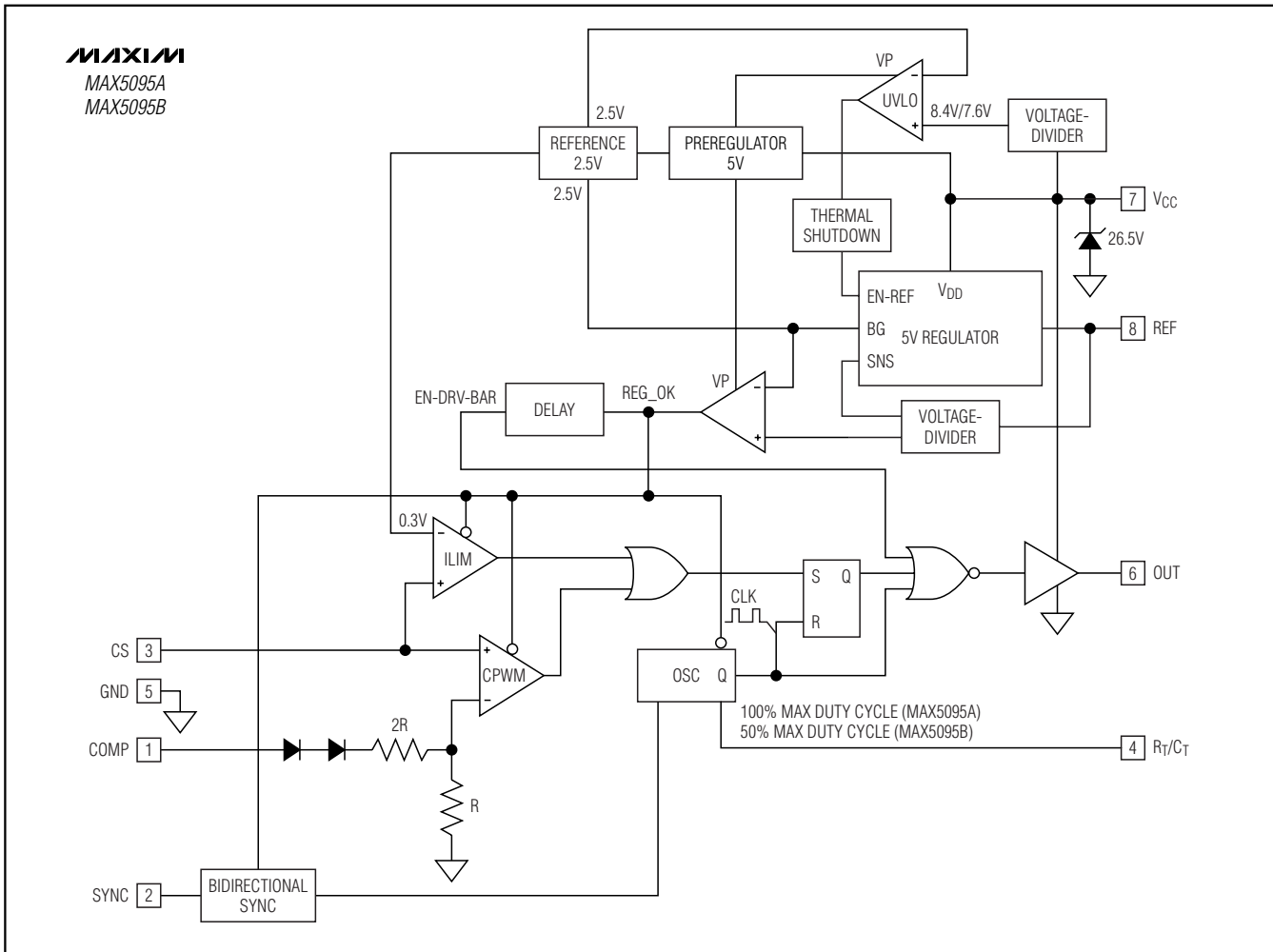

Figure 2. MAX5095A/B Functional Diagram

### Current-Mode Control Loop

The advantages of current-mode control over voltage-mode control are twofold. First, there is the feed-forward characteristic brought on by the controller's ability to adjust for variations in the input voltage on a cycle-by-cycle basis. Secondly, the stability requirements of the current-mode controller are reduced to that of a single-pole system unlike the double pole in the voltage-mode control scheme.

The MAX5094/MAX5095 use a current-mode control loop where the output of the error amplifier is compared to the current-sense voltage ( $V_{CS}$ ). When the current-sense signal is lower than the inverting input of the CPWM comparator, the output of the comparator is low and the switch is turned on at each clock pulse. When the current-sense signal is higher than the inverting input of the CPWM comparator, the output is high and the switch is turned off.

# High-Performance, Single-Ended, Current-Mode PWM Controllers

MAX5094A/B/C/D/MAX5095A/B/C

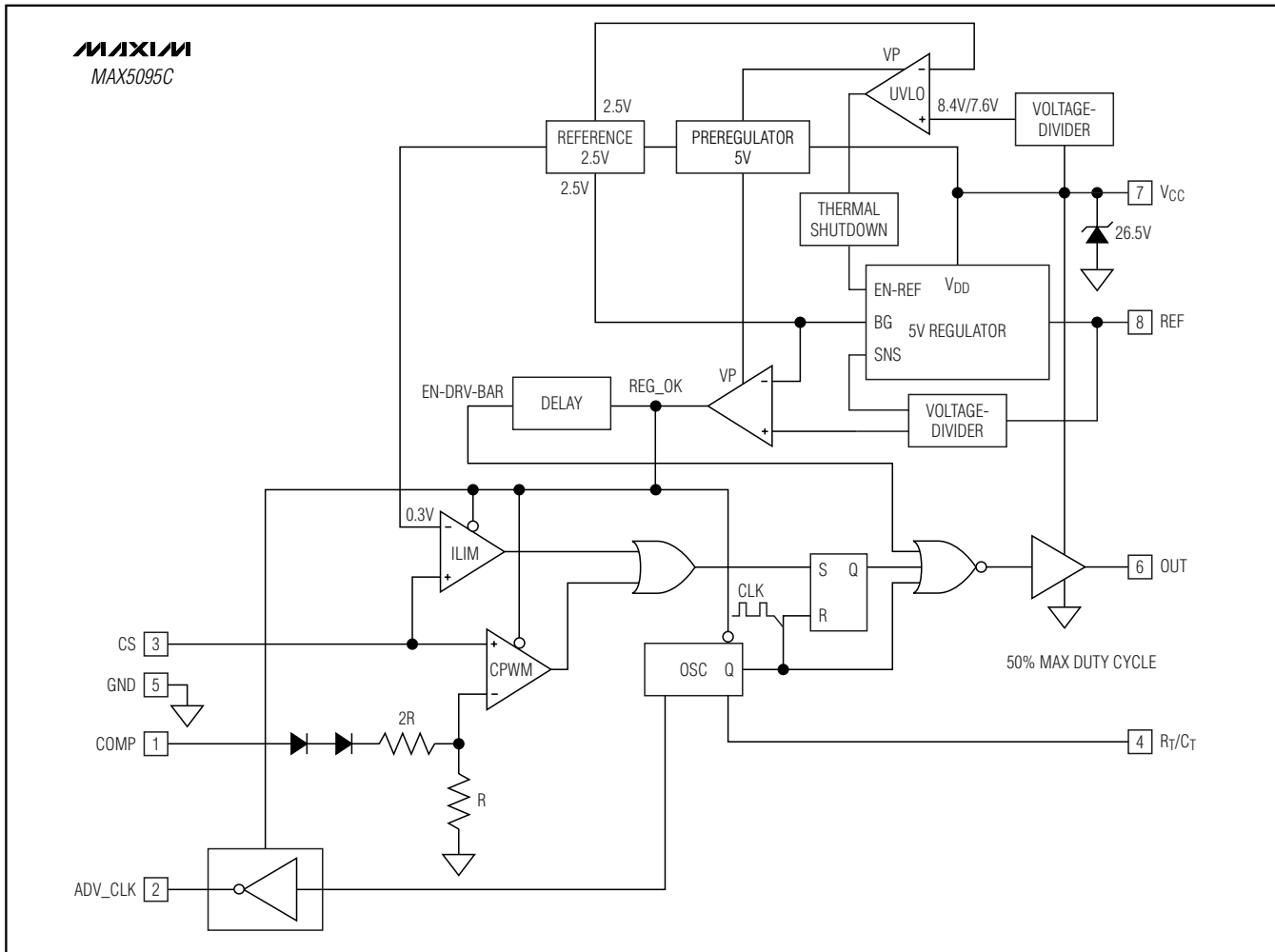

Figure 3. MAX5095C Functional Diagram

## V<sub>CC</sub> and Startup

In normal operation, V<sub>CC</sub> is derived from a tertiary winding of the transformer. However, at startup there is no energy delivered through the transformer, thus a resistor must be connected from V<sub>CC</sub> to the input power source (see R<sub>ST</sub> and C<sub>ST</sub> in Figures 5 to 8). During startup, C<sub>ST</sub> charges up through R<sub>ST</sub>. The 5V reference generator, comparator, error amplifier, oscillator, and drive circuit remain off during UVLO to reduce startup current below 65μA. When V<sub>CC</sub> reaches the undervoltage-lockout threshold of 8.4V, the output driver begins to switch and the tertiary winding supplies power to V<sub>CC</sub>. V<sub>CC</sub> has an internal 26.5V current-limited clamp at its input to protect the device from overvoltage during startup.

Size the startup resistor, R<sub>ST</sub>, to supply both the maximum startup bias (I<sub>START</sub>) of the device (65μA max) and the charging current for C<sub>ST</sub>. The startup capacitor C<sub>ST</sub> must charge to 8.4V within the desired time period t<sub>ST</sub> (for example, 500ms). The size of the startup capacitor depends on:

- 1) IC operating supply current at a programmed oscillator frequency (f<sub>OSC</sub>).
- 2) The time required for the bias voltage, derived from a bias winding, to go from 0 to 9V.
- 3) The MOSFET total gate charge.
- 4) The operating frequency of the converter (f<sub>sw</sub>).

# High-Performance, Single-Ended, Current-Mode PWM Controllers

To calculate the capacitance required, use the following formula:

$$C_{ST} = \frac{(I_{CC} + I_G)(t_{SS})}{V_{HYST}}$$

where:

$$I_G = Q_G f_{SW}$$

$I_{CC}$  is the MAX5094/MAX5095's maximum internal supply current after startup (see the *Typical Operating Characteristics* to find the  $I_{IN}$  at a given  $f_{OSC}$ ).  $Q_G$  is the total gate charge for the MOSFET,  $f_{SW}$  is the converter switching frequency,  $V_{HYST}$  is the bootstrap UVLO hysteresis (0.8V), and  $t_{SS}$  is the soft-start time, which is set by external circuitry.

Size the resistor  $R_{ST}$  according to the desired startup time period,  $t_{ST}$ , for the calculated  $C_{ST}$ . Use the following equations to calculate the average charging current ( $I_{CST}$ ) and the startup resistor ( $R_{ST}$ ):

$$I_{CST} = \frac{V_{SUVR} \times C_{ST}}{t_{ST}}$$

$$R_{ST} \cong \frac{\left( V_{INMIN} - \frac{V_{SUVR}}{2} \right)}{I_{CST} + I_{START}}$$

Where  $V_{INMIN}$  is the minimum input supply voltage for the application (36V for telecom),  $V_{SUVR}$  is the bootstrap UVLO wake-up level (8.4V), and  $I_{START}$  is the  $V_{IN}$  supply current at startup (65 $\mu$ A, max). Choose a higher value for  $R_{ST}$  than the one calculated above if longer startup times can be tolerated to minimize power loss in  $R_{ST}$ .

The equation for  $C_{ST}$  above gives a good approximation of  $C_{ST}$ , yet neglects the current through  $R_{ST}$ . Fine tune  $C_{ST}$  using:

$$C_{ST} = \left[ \frac{I_{CC} + I_G - \left( \frac{V_{INMIN} - 8V}{R_{ST}} \right)}{V_{HYST}} \right] (t_{SS})$$

The above startup method is applicable to circuits where the tertiary winding has the same phase as the output windings. Thus, the voltage on the tertiary winding at any given time is proportional to the output voltage and goes through the same soft-start period as the output voltage.

The minimum discharge time of  $C_{ST}$  from 8.4V to 7.6V must be greater than the soft-start time ( $t_{SS}$ ).

## Undervoltage Lockout (UVLO)

The minimum turn-on supply voltage for the MAX5094/MAX5095 is 8.4V. Once  $V_{CC}$  reaches 8.4V, the reference powers up. There is 0.8V of hysteresis from the minimum turn-on voltage to the UVLO threshold. Once  $V_{CC}$  reaches 8.4V, the MAX5094/MAX5095 operates with  $V_{CC}$  down to 7.6V. Once  $V_{CC}$  goes below 7.6V the device is in UVLO. When in UVLO, the quiescent supply current into  $V_{CC}$  falls back to 32 $\mu$ A (typ), and OUT and REF are pulled low.

## MOSFET Driver

OUT drives an external n-channel MOSFET and swings from GND to  $V_{CC}$ . Ensure that  $V_{CC}$  remains below the absolute maximum  $V_{GS}$  rating of the external MOSFET. OUT is a push-pull output with the on-resistance of the PMOS typically 3.5 $\Omega$  and the on-resistance of the NMOS typically 4.5 $\Omega$ . The driver can source 2A typically and sink 1A typically. This allows for the MAX5094/MAX5095 to quickly turn on and off high gate-charge MOSFETs.

Bypass  $V_{CC}$  with one or more 0.1 $\mu$ F ceramic capacitors to GND, placed close to the MAX5094/MAX5095. The average current sourced to drive the external MOSFET depends on the total gate charge ( $Q_G$ ) and operating frequency of the converter. The power dissipation in the MAX5094/MAX5095 is a function of the average output-drive current ( $I_{DRIVE}$ ). Use the following equation to calculate the power dissipation in the device due to  $I_{DRIVE}$ :

$$I_{DRIVE} = Q_G \times f_{SW}$$

$$PD = (I_{DRIVE} + I_{CC}) \times V_{CC}$$

where,  $I_{CC}$  is the operating supply current. See the *Typical Operating Characteristics* for the operating supply current at a given frequency.

## Error Amplifier (MAX5094)

The MAX5094 includes an internal error amplifier. The inverting input is at FB and the noninverting input is internally connected to a 2.5V reference. The internal error amplifier is useful for nonisolated converter design (see Figure 6) and isolated design with primary-side regulation through a bias winding (see Figure 5). In the case of a nonisolated power supply, the output voltage is:

$$V_{OUT} = \left( 1 + \frac{R_1}{R_2} \right) \times 2.5V$$

where,  $R_1$  and  $R_2$  are from Figure 6.

# High-Performance, Single-Ended, Current-Mode PWM Controllers

## MAX5095 Feedback

The MAX5095A/MAX5095B/MAX5095C use either an external error amplifier when designed into a nonisolated converter or an error amplifier and optocoupler when designed into an isolated power supply. The COMP input is level-shifted and connected to the inverting terminal of the PWM comparator (CPWM). Connect the COMP input to the output of the external error amplifier for nonisolated design. Pull COMP high externally to 5V (or REF) and connect the optocoupler transistor as shown in Figures 7 and 8. COMP can be used for soft-start and also as a shutdown. See the *Typical Operating Characteristics* to find the turn-off COMP voltage at different temperatures.

## Oscillator

The oscillator frequency is programmed by adding an external capacitor and resistor at  $R_T/C_T$  (see  $R_T$  and  $C_T$  in the *Typical Application Circuits*).  $R_T$  is connected from  $R_T/C_T$  to the 5V reference (REF) and  $C_T$  is connected from  $R_T/C_T$  to GND. REF charges  $C_T$  through  $R_T$  until its voltage reaches 2.8V.  $C_T$  then discharges through an 8.3mA internal current sink until  $C_T$ 's voltage reaches 1.1V, at which time  $C_T$  is allowed to charge through  $R_T$  again. The oscillator's period will be the sum of the charge and discharge times of  $C_T$ . Calculate the charge time as

$$t_C = 0.57 \times R_T \times C_T$$

The discharge time is then

$$t_D = \frac{R_T \times C_T \times 10^3}{4.88 \times R_T - 1.8 \times 10^3}$$

The oscillator frequency will then be

$$f_{OSC} = \frac{1}{t_C + t_D}$$

For the MAX5094A/MAX5094C/MAX5095A, the converter output switching frequency ( $f_{sw}$ ) is the same as the oscillator frequency ( $f_{OSC}$ ). For the MAX5094B/MAX5094D/MAX5095B/MAX5095C, the output switching frequency is 1/2 the oscillator frequency.

## Reference Output

REF is a 5V reference output that can source 20mA. Bypass REF to GND with a 0.1 $\mu$ F capacitor.

## Current Limit

The MAX5094/MAX5095 include a fast current-limit comparator to terminate the ON cycle during an overload or a fault condition. The current-sense resistor ( $R_{CS}$ ), connected between the source of the MOSFET and GND, sets the current limit. The CS input has a voltage trip level ( $V_{CS}$ ) of 1V (MAX5094A/B) or 0.3V (MAX5094C/D, MAX5095\_). Use the following equation to calculate  $R_{CS}$ :

$$R_{CS} = \frac{V_{CS}}{I_{P-P}}$$

$I_{P-P}$  is the peak current in the primary that flows through the MOSFET. When the voltage produced by this current (through the current-sense resistor) exceeds the current-limit comparator threshold, the MOSFET driver (OUT) will turn the switch off within 60ns. In most cases, a small RC filter is required to filter out the leading-edge spike on the sense waveform. Set the time constant of the RC filter at 50ns. Use a current transformer to limit the losses in the current-sense resistor and achieve higher efficiency especially at low input-voltage operation.

## Synchronization (MAX5095A/MAX5095B)

### SYNC

SYNC is a bidirectional input/output that outputs a synchronizing pulse and accepts a synchronizing pulse from other MAX5095A/MAX5095Bs (see Figures 7 and 9). As an output, SYNC is an open-drain p-channel MOSFET driven from the internal oscillator and requires an external pulldown resistor ( $R_{SYNC}$ ) between 500 $\Omega$  and 5k $\Omega$ . As an input, SYNC accepts the output pulses from other MAX5095A/MAX5095Bs.

Synchronize multiple MAX5095A/MAX5095Bs by connecting their SYNC pins together. All devices connected together will synchronize to the one operating at the highest frequency. The rising edge of SYNC will precede the rising edge of OUT by approximately the discharge time ( $t_D$ ) of the oscillator (see the *Oscillator* section). The pulse width of the SYNC output is equal to the time required to discharge the stray capacitance at SYNC through  $R_{SYNC}$  plus the  $C_T$  discharge time  $t_D$ . Adjust  $R_T/C_T$  such that the minimum discharge time  $t_D$  is 200ns.

# High-Performance, Single-Ended, Current-Mode PWM Controllers

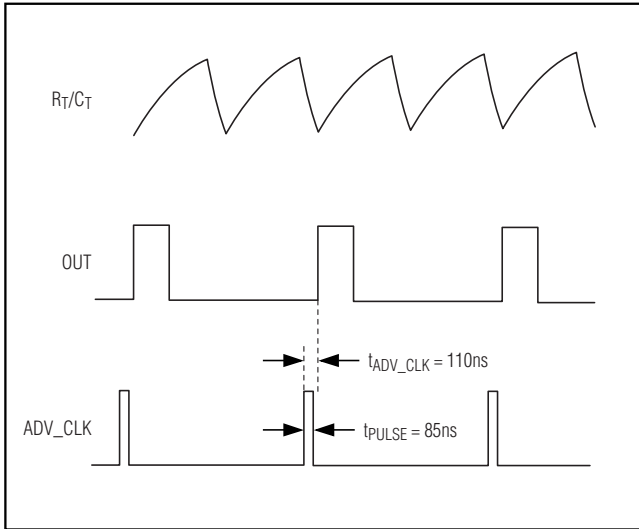

Figure 4. ADV\_CLK

### Advance Clock Output (ADV\_CLK) (MAX5095C)

ADV\_CLK is an advanced pulse output provided to facilitate the easy implementation of secondary-side synchronous rectification using the MAX5095C. The ADV\_CLK pulse width is 85ns (typically) with its rising edge leading the rising edge of OUT by 110ns. Use this leading pulse to turn off the secondary-side synchronous-rectifier MOSFET (QS) before the voltage appears on the secondary (see Figure 8). Turning off the secondary-side synchronous MOSFET earlier avoids the shorting of the secondary in the forward converter. The ADV\_CLK pulse can be propagated to the secondary side using a pulse transformer or high-speed optocoupler. The 85ns pulse, with 3V drive voltage (10mA source), significantly reduces the volt-second requirement of the pulse transformer and the advanced pulse alleviates the need for a high-speed optocoupler.

### Thermal Shutdown

When the MAX5094/MAX5095's die temperature goes above +150°C, the thermal shutdown circuitry will shut down the 5V reference and pull OUT low.

## Typical Application Circuits

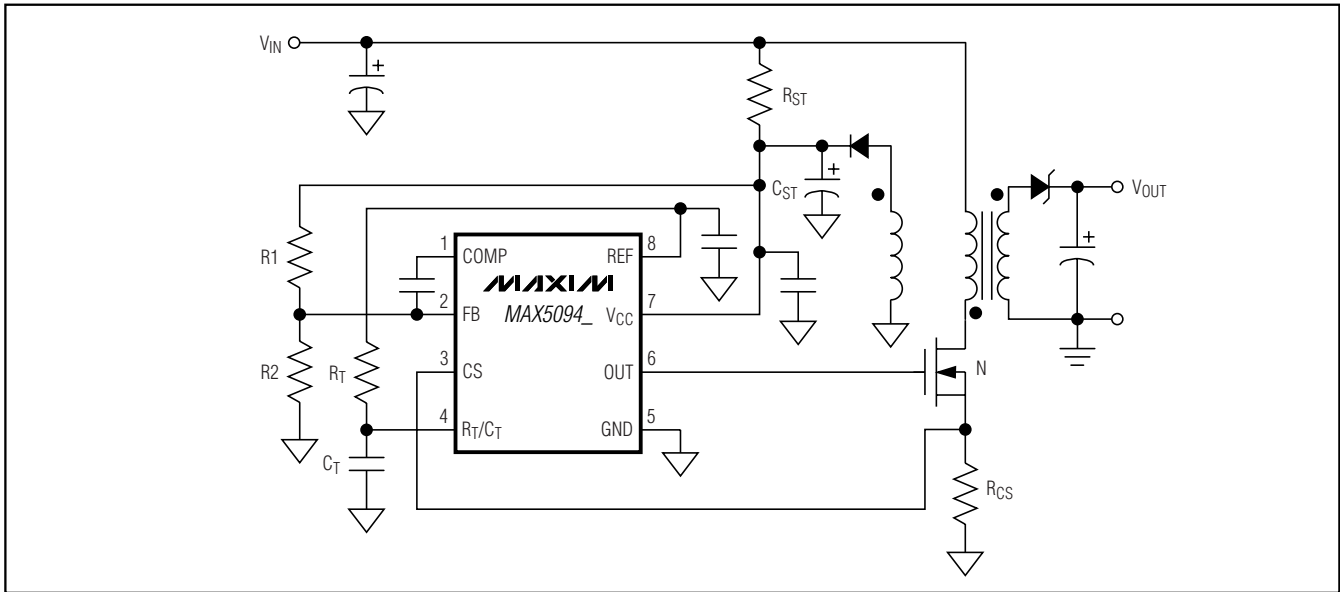

Figure 5. MAX5094\_ Typical Application Circuit (Isolated Flyback with Primary-Side Regulation)



# High-Performance, Single-Ended, Current-Mode PWM Controllers

## Typical Application Circuits (continued)

MAX5094A/B/C/D/MAX5095A/B/C

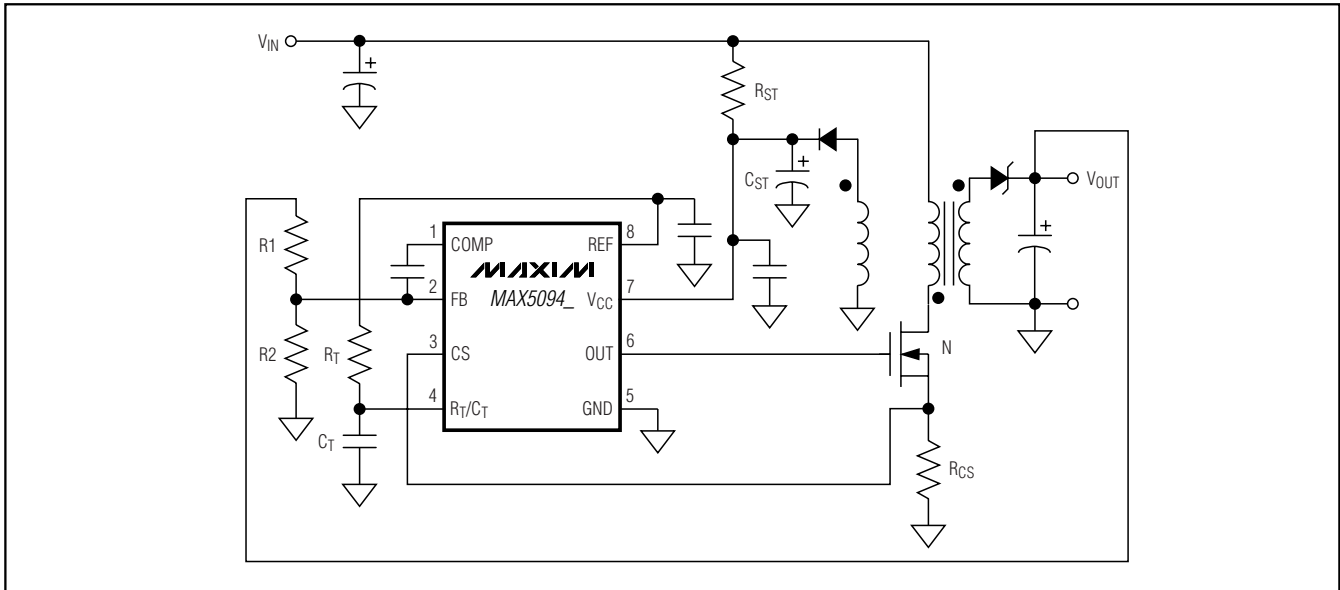

Figure 6. MAX5094\_ Typical Application Circuit (Nonisolated Flyback)

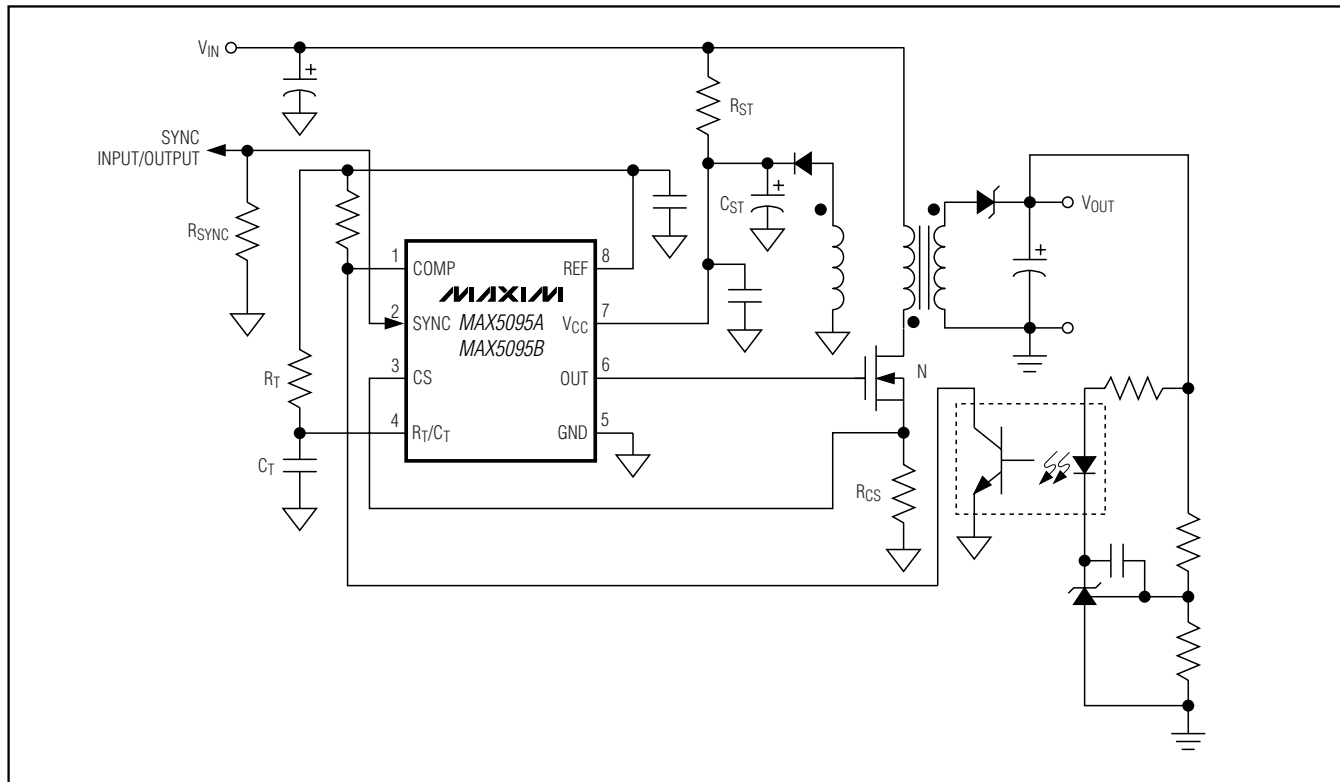

Figure 7. MAX5095A/MAX5095B Typical Application Circuit (Isolated Flyback)

# High-Performance, Single-Ended, Current-Mode PWM Controllers

## Typical Application Circuits (continued)

**MAX5094A/B/C/D/MAX5095A/B/C**

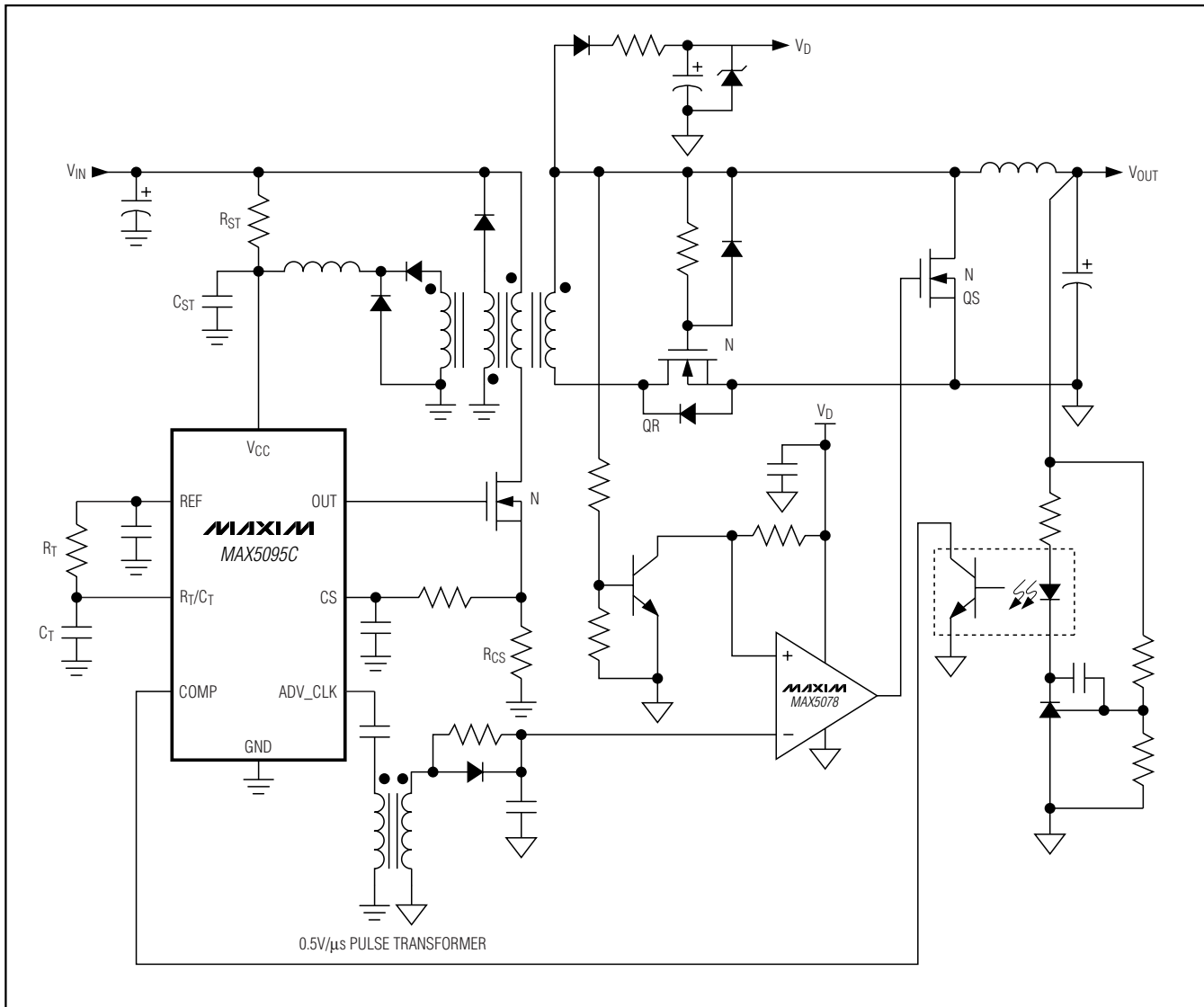

Figure 8. MAX5095C Typical Application Circuit (Isolated Forward with Secondary-Side Synchronous Rectification)

# High-Performance, Single-Ended, Current-Mode PWM Controllers

MAX5094A/B/C/D/MAX5095A/B/C

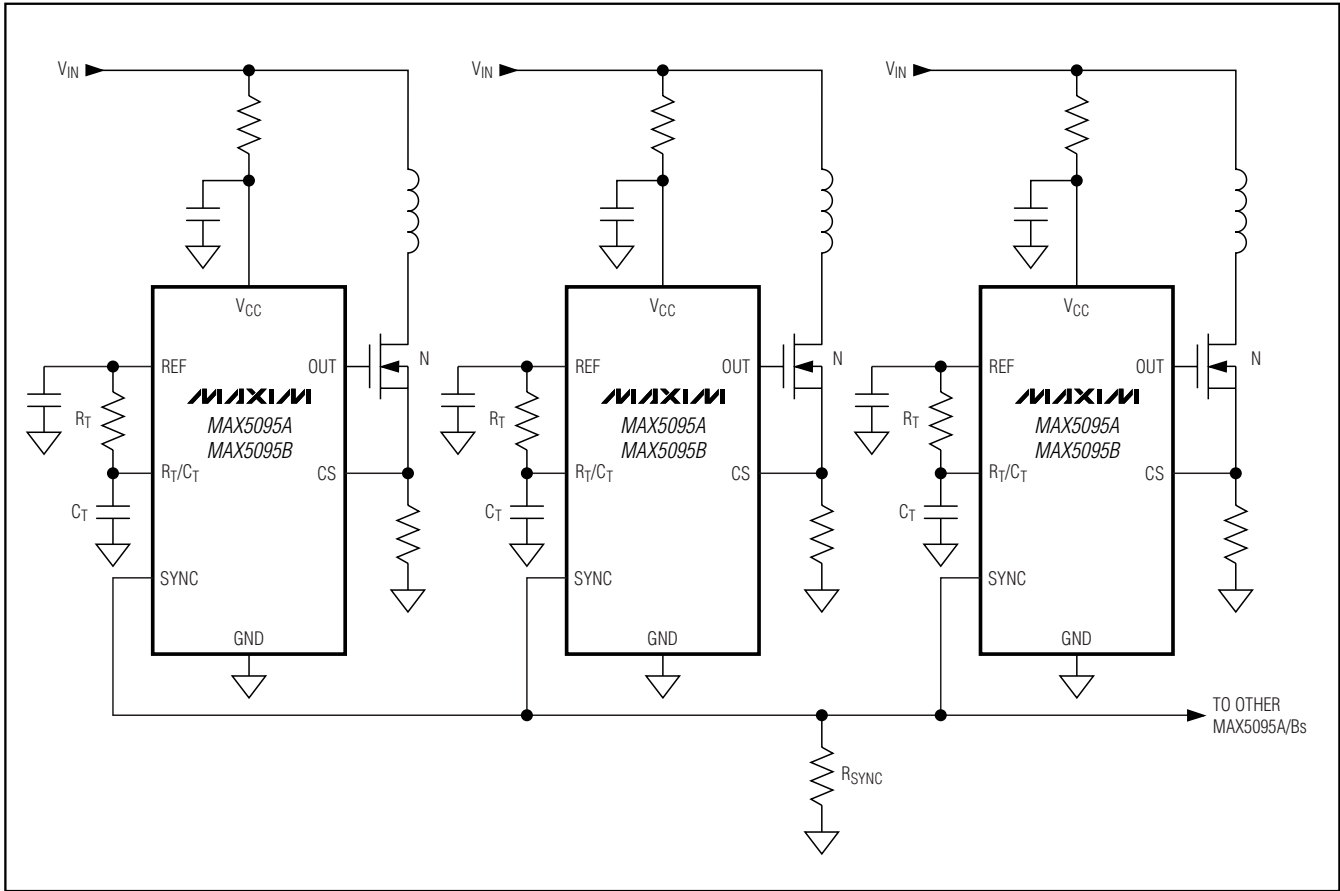

Figure 9. Synchronization of MAX5095A/MAX5095B

# High-Performance, Single-Ended, Current-Mode PWM Controllers

## Selector Guide

PART	FEATURE	UVLO THRESHOLD (V)	CS THRESHOLD (V)	MAX DUTY CYCLE (%)	COMPETITORS PART NUMBER	PIN-PACKAGE
MAX5094AASA	Feedback	8.4	1	100	UCC28C43 2nd source	8 SO
MAX5094AAUA	Feedback	8.4	1	100	UCC28C43 2nd source	8 $\mu$ MAX
MAX5094BASA	Feedback	8.4	1	50	UCC28C45 2nd source	8 SO
MAX5094BAUA	Feedback	8.4	1	50	UCC28C45 2nd source	8 $\mu$ MAX
MAX5094CASA	Feedback	8.4	0.3	100	Improved UCC28C43	8 SO
MAX5094CAUA	Feedback	8.4	0.3	100	Improved UCC28C43	8 $\mu$ MAX
MAX5094DAUA	Feedback	8.4	0.3	50	Improved UCC28C45	8 $\mu$ MAX
MAX5095AAUA	Sync	8.4	0.3	100	Improved UCC28C43	8 $\mu$ MAX
MAX5095BAUA	Sync	8.4	0.3	50	Improved UCC28C45	8 $\mu$ MAX
MAX5095CAUA	ADV_CLK	8.4	0.3	50	Improved UCC28C45	8 $\mu$ MAX

## Pin Configurations (continued)

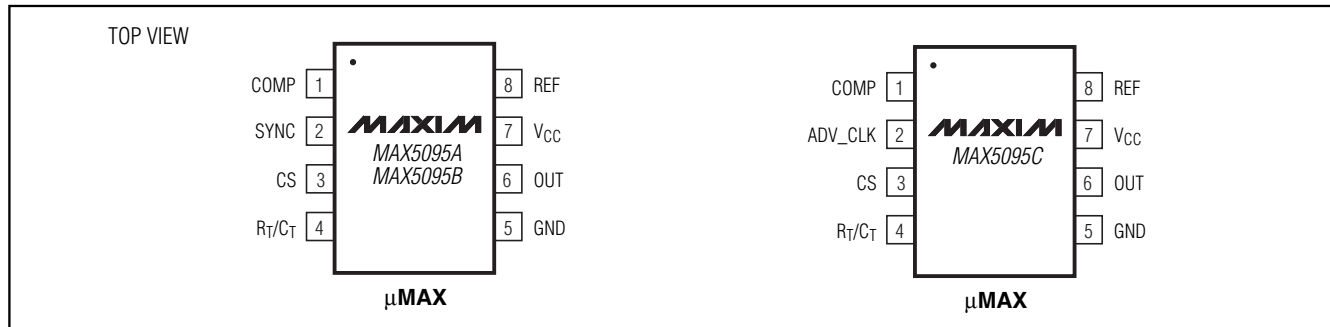

## Ordering Information (continued)

PART	TEMP RANGE	PIN-PACKAGE	PKG CODE
MAX5094CASA*	-40°C to +125°C	8 SO	S8-4
MAX5094CASA+	-40°C to +125°C	8 SO	S8-4
MAX5094CAUA*	-40°C to +125°C	8 $\mu$ MAX	U8-1
MAX5094CAUA+	-40°C to +125°C	8 $\mu$ MAX	U8-1
MAX5094DAUA*	-40°C to +125°C	8 $\mu$ MAX	U8-1
MAX5094DAUA+	-40°C to +125°C	8 $\mu$ MAX	U8-1
MAX5095AAUA	-40°C to +125°C	8 $\mu$ MAX	U8-1
MAX5095AAUA+*	-40°C to +125°C	8 $\mu$ MAX	U8-1
MAX5095BAUA*	-40°C to +125°C	8 $\mu$ MAX	U8-1
MAX5095BAUA+	-40°C to +125°C	8 $\mu$ MAX	U8-1
MAX5095CAUA*	-40°C to +125°C	8 $\mu$ MAX	U8-1
MAX5095CAUA+	-40°C to +125°C	8 $\mu$ MAX	U8-1

+ Denotes lead-free package.

\* Future product—contact factory for availability.

## Chip Information

TRANSISTOR COUNT: 1987

PROCESS: BiCMOS

# High-Performance, Single-Ended, Current-Mode PWM Controllers

## Package Information

(The package drawing(s) in this data sheet may not reflect the most current specifications. For the latest package outline information go to [www.maxim-ic.com/packages](http://www.maxim-ic.com/packages).)

MAX5094A/B/C/D/MAX5095A/B/C

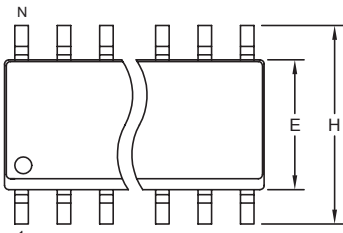

TOP VIEW

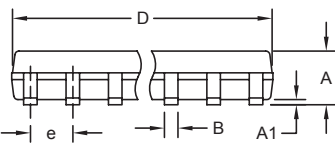

FRONT VIEW

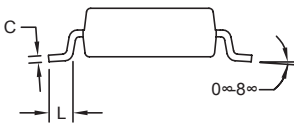

SIDE VIEW

DIM	INCHES		MILLIMETERS	
	MIN	MAX	MIN	MAX
A	0.053	0.069	1.35	1.75
A1	0.004	0.010	0.10	0.25
B	0.014	0.019	0.35	0.49
C	0.007	0.010	0.19	0.25
e	0.050 BSC		1.27 BSC	
E	0.150	0.157	3.80	4.00
H	0.228	0.244	5.80	6.20
L	0.016	0.050	0.40	1.27

VARIATIONS:

DIM	INCHES		MILLIMETERS		N	MS012
	MIN	MAX	MIN	MAX		
D	0.189	0.197	4.80	5.00	8	AA
D	0.337	0.344	8.55	8.75	14	AB
D	0.386	0.394	9.80	10.00	16	AC

**NOTES:**

- D&E DO NOT INCLUDE MOLD FLASH.
- MOLD FLASH OR PROTRUSIONS NOT TO EXCEED 0.15mm (.006").
- LEADS TO BE COPLANAR WITHIN 0.10mm (.004").
- CONTROLLING DIMENSION: MILLIMETERS.
- MEETS JEDEC MS012.
- N = NUMBER OF PINS.

**DALLAS SEMICONDUCTOR** **MAXIM**

PROPRIETARY INFORMATION

TITLE:  
PACKAGE OUTLINE, .150" SOIC

APPROVAL	DOCUMENT CONTROL NO. 21-0041	REV. B	1/1
----------	---------------------------------	-----------	-----

SOIC LEPS

# High-Performance, Single-Ended, Current-Mode PWM Controllers

## Package Information (continued)

(The package drawing(s) in this data sheet may not reflect the most current specifications. For the latest package outline information go to [www.maxim-ic.com/packages](http://www.maxim-ic.com/packages).)

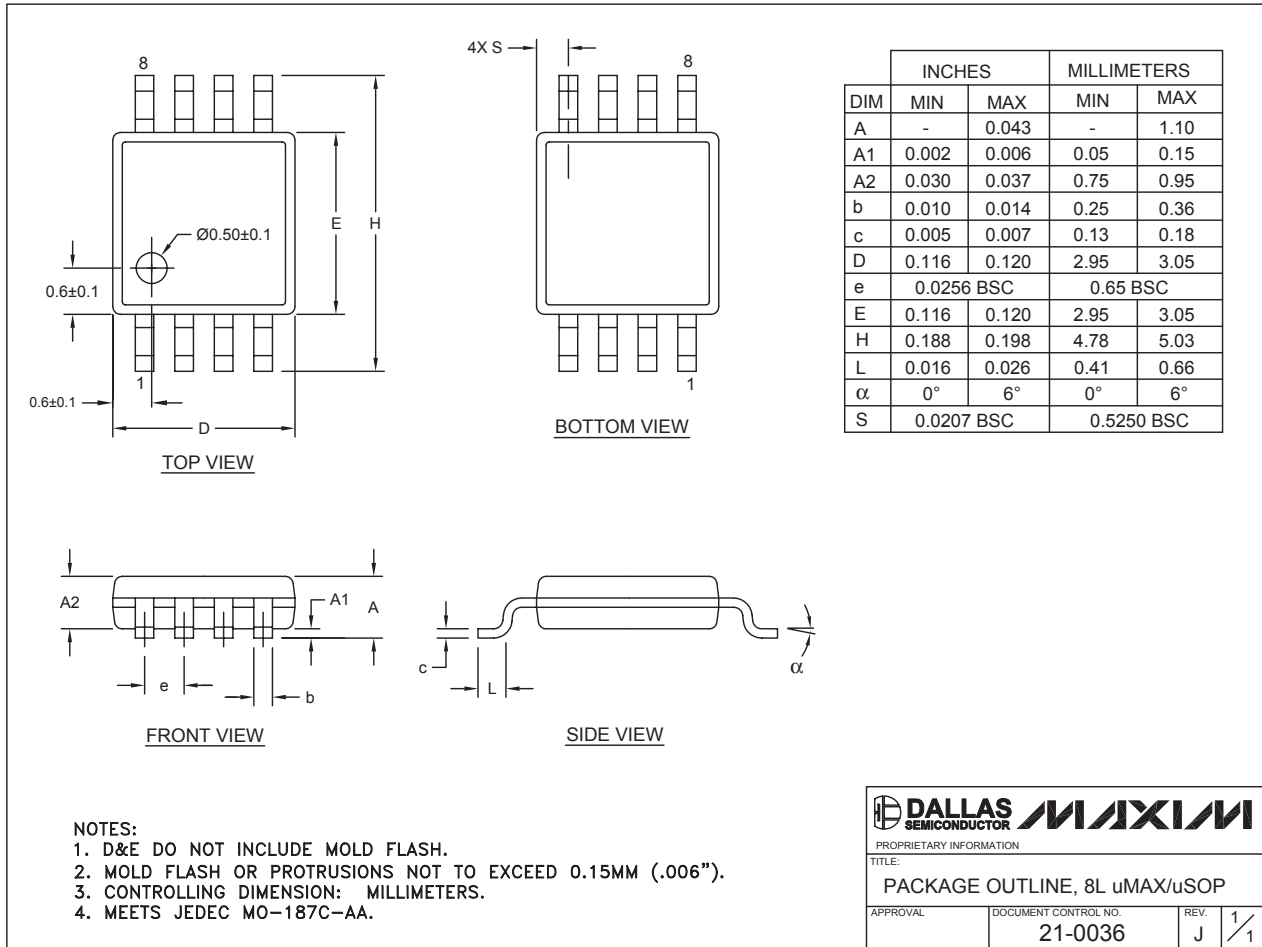

Maxim cannot assume responsibility for use of any circuitry other than circuitry entirely embodied in a Maxim product. No circuit patent licenses are implied. Maxim reserves the right to change the circuitry and specifications without notice at any time.

22 **Maxim Integrated Products, 120 San Gabriel Drive, Sunnyvale, CA 94086 408-737-7600**



Компания «ЭлектроПласт» предлагает заключение долгосрочных отношений при поставках импортных электронных компонентов на взаимовыгодных условиях!

Наши преимущества:

- Оперативные поставки широкого спектра электронных компонентов отечественного и импортного производства напрямую от производителей и с крупнейших мировых складов;
- Поставка более 17-ти миллионов наименований электронных компонентов;
- Поставка сложных, дефицитных, либо снятых с производства позиций;
- Оперативные сроки поставки под заказ (от 5 рабочих дней);
- Экспресс доставка в любую точку России;
- Техническая поддержка проекта, помощь в подборе аналогов, поставка прототипов;
- Система менеджмента качества сертифицирована по Международному стандарту ISO 9001;
- Лицензия ФСБ на осуществление работ с использованием сведений, составляющих государственную тайну;
- Поставка специализированных компонентов (Xilinx, Altera, Analog Devices, Intersil, Interpoint, Microsemi, Aeroflex, Peregrine, Syfer, Eurofarad, Texas Instrument, Miteq, Cobham, E2V, MA-COM, Hittite, Mini-Circuits, General Dynamics и др.);

Помимо этого, одним из направлений компании «ЭлектроПласт» является направление «Источники питания». Мы предлагаем Вам помощь Конструкторского отдела:

- Подбор оптимального решения, техническое обоснование при выборе компонента;
- Подбор аналогов;
- Консультации по применению компонента;
- Поставка образцов и прототипов;
- Техническая поддержка проекта;
- Защита от снятия компонента с производства.



#### Как с нами связаться

**Телефон:** 8 (812) 309 58 32 (многоканальный)

**Факс:** 8 (812) 320-02-42

**Электронная почта:** [org@eplast1.ru](mailto:org@eplast1.ru)

**Адрес:** 198099, г. Санкт-Петербург, ул. Калинина, дом 2, корпус 4, литера А.