

1 2 3 4 5 6 7 8
 1 0 1 3 0 1 0 4 - X 0 E - X X X L F

8-COLUMN DIFFERENTIAL SIGNAL

LEAD-FREE DESIGNATION ONLY WITH APPLICABLE PLATING CODES

LETTER	PERFORMANCE-BASED PLATING (SEE NOTE 2)	
	TARGET APPLICATION	LEAD FREE (LF)
K	TELCORDIA CO	NO
M	TELCORDIA CO	YES

NUMBER	GUIDE PIN STYLE (SEE NOTE 8)	NOT TOOLED
0	STANDARD GUIDE PIN, MACHINED	
1	STANDARD GUIDE PIN, ROLLED	

NUMBER	CONTACT MATING WIPE LENGTH		COMPLIANT TAIL TYPE (SEE NOTE 9)
	SIGNAL	GROUND	
1	2 MM	4 MM	0.55 (0.0217") DRILL
2	3 MM	4 MM	0.55 (0.0217") DRILL
3	2 MM	4 MM	0.45 MICRO (0.0177") DRILL
4	3 MM	4 MM	0.45 MICRO (0.0177") DRILL
5	2 MM	3 MM	0.55 (0.0217") DRILL
6	3 MM	3 MM	0.55 (0.0217") DRILL
7	2 MM	3 MM	0.45 MICRO (0.0177") DRILL
8	3 MM	3 MM	0.45 MICRO (0.0177") DRILL

FOR CUSTOM-LOADED MODULES, SEE INDIVIDUAL CUSTOM DRAWINGS WITH THE DRAWING-NUMBER FORMAT OF 10130104-XXXX, WHERE: "X" DENOTES MODULE TYPE PER CHART ON THIS SHEET "YYYY" IS A SEQUENTIAL NUMBER BEGINNING WITH "0001".

MODULE DESCRIPTION	LETTER DESIGNATION REPRESENTED IN DASH NUMBER										BASE MODULE	
LEFT POLARIZING GUIDANCE MODULE (SEE SHEET 6)	N	J	A	B	C	D	E	F	G	H		
	NO KEY NO GUIDE PIN											
RIGHT POLARIZING GUIDANCE MODULE (SEE SHEET 7)	Z	Y	P	Q	R	S	T	U	V	W		
	NO KEY NO GUIDE PIN											
OPEN MODULE (TWO WALL) (SEE SHEET 2)	0 (ZERO)											
LEFT WALL MODULE (SEE SHEET 3)	L											
RIGHT WALL MODULE (SEE SHEET 4)	M											
FOUR WALL MODULE (SEE SHEET 5)	1 (ONE)											

	UNGROUNDED	GROUNDED
FHS	Ø2.35-Ø2.55	Ø2.35-Ø2.55
PAD	N/A	Ø5.50
PLATED	NO	YES
DRILL(mm)	2.44mm	2.58mm
DRILL(in)	0.096"	0.1015"

SCREW P/N	DESCRIPTION	BOARD THICKNESS
10091790-002LF	#2-56 X 0.375" LG. PHILIPS PANHEAD W/SQ CONICAL WASHER	1.60-5.00mm
10091790-003LF	#2-56 X 0.375" LG. PHILIPS PANHEAD W/SQ CONICAL WASHER	5.00-10.00mm

spec ref		TOLERANCES UNLESS OTHERWISE SPECIFIED		
tolerance std	ISO 406 ISO 1101	0.X	±0.3	
surface	linear	0.XX	±0.10	
		0.XXX	±0.05	
		angular	0°	±2°

dr	Sandar Soe	2014/05/16	projection	mm	size	A2	scale	1:1
eng	Sandar Soe	2015/10/30		←→	ecn no	ELX-S-18192-1		
chr	-	-			rel level	Released		
appr	Chen-Hong Tan	2015/11/02	product family	-	cat. no.	-	Product - Customer Drw	sheet 1 of 8
		title		MODULE ASSEMBLY, XCEDE HD		cat. no.	10130104	rev
www.fci.com		Veritcal Header, 4 Pair 8 Column						B

Copyright FCI. FCI

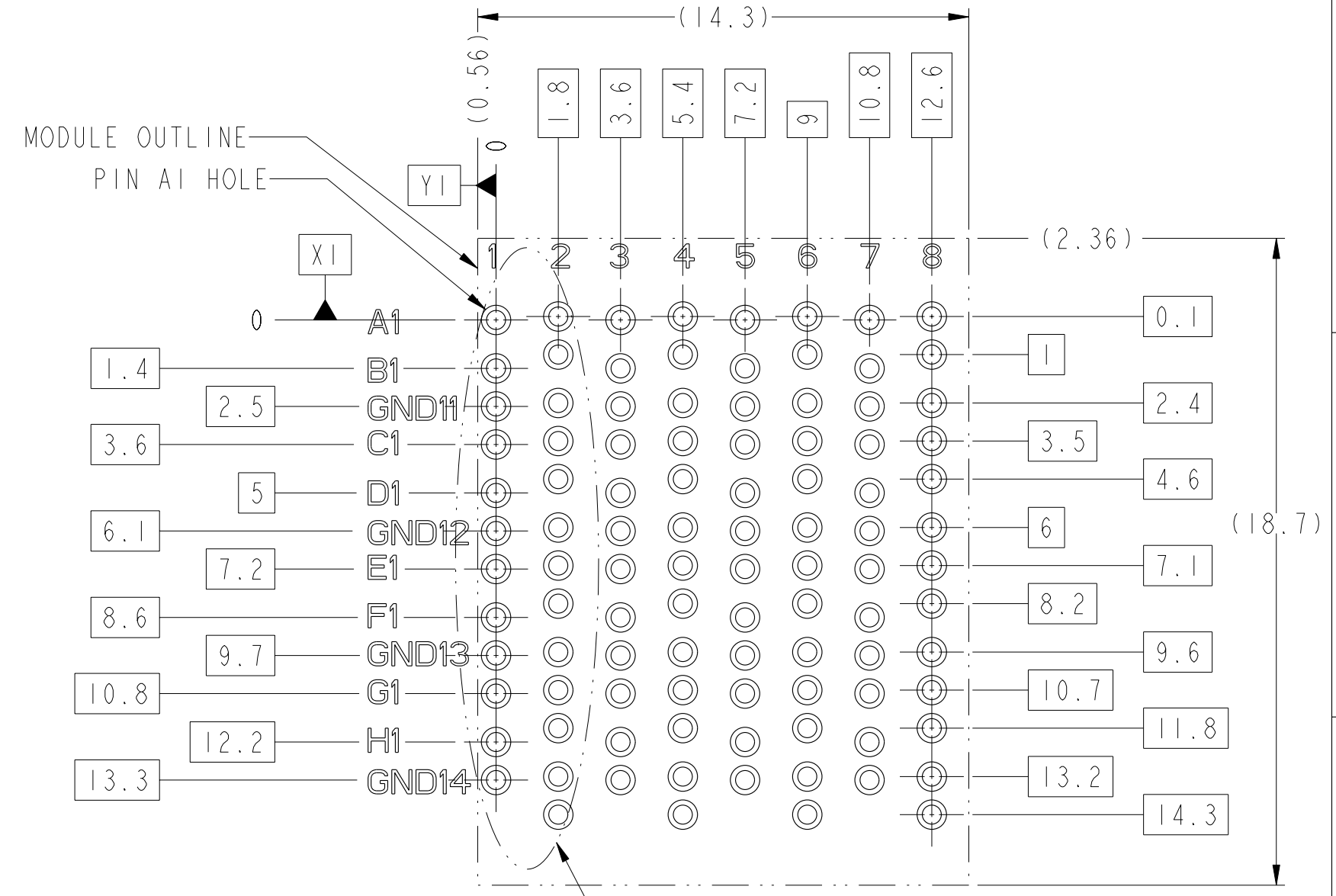
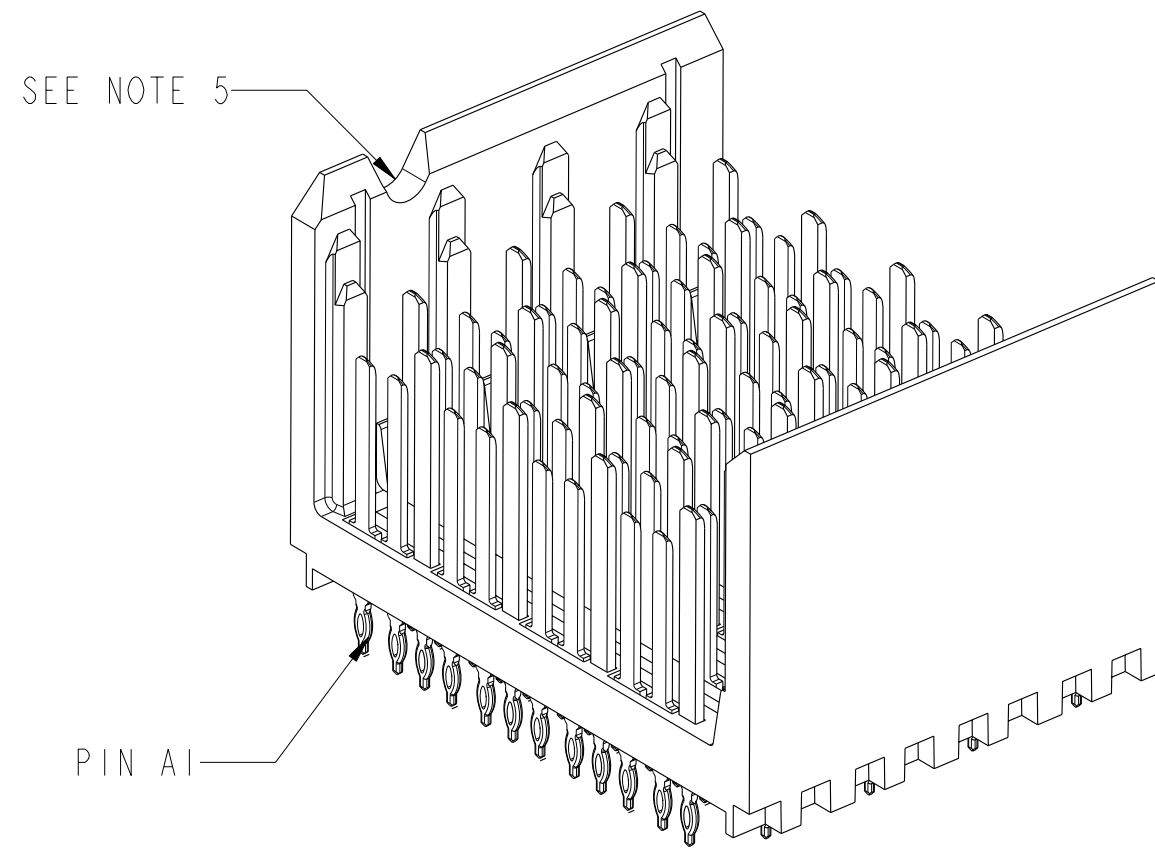
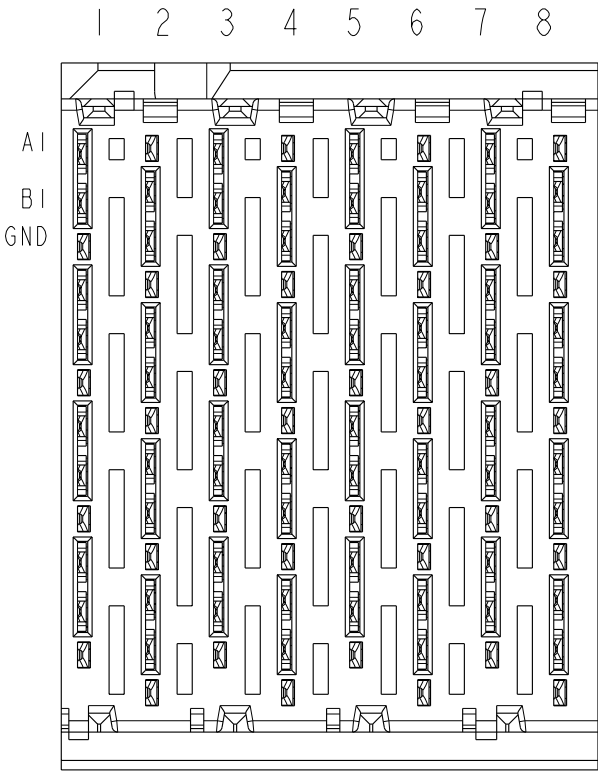

SEE DETAIL A
On Sheet 8 For Details

BP HOLE PATTERN COMPONENT SIDE
OPEN WALL MODULE BACKPLANE FOOTPRINT

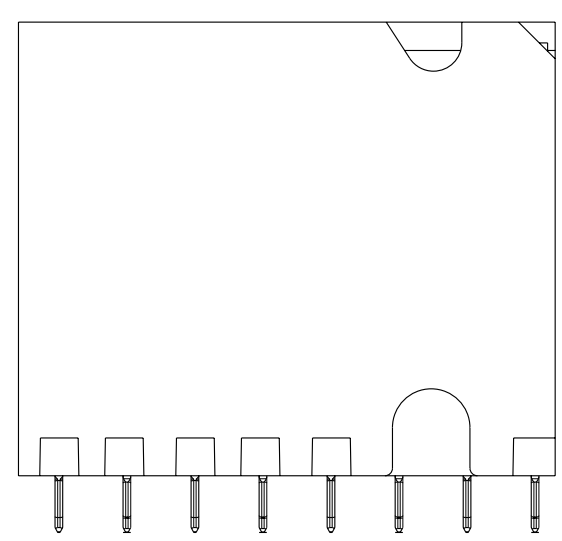
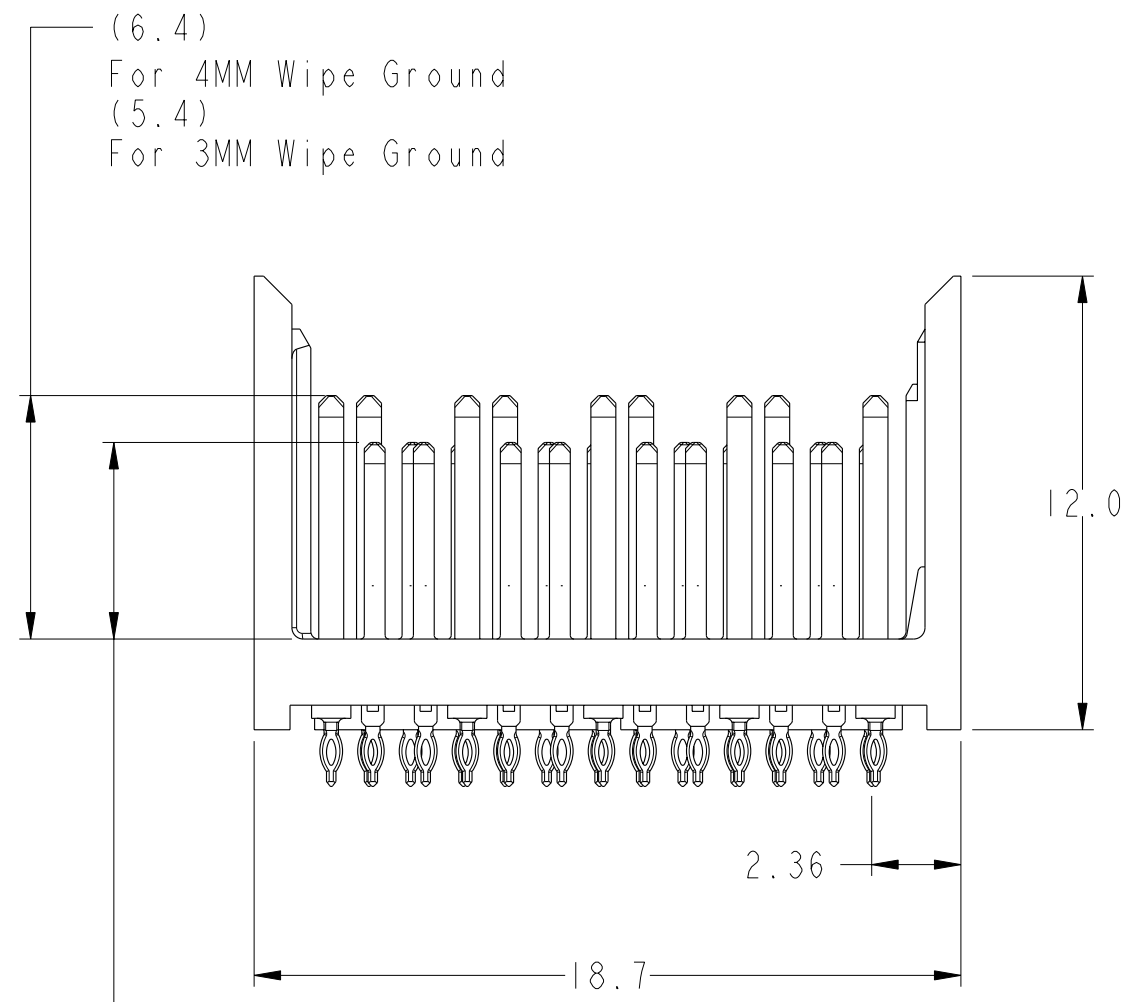
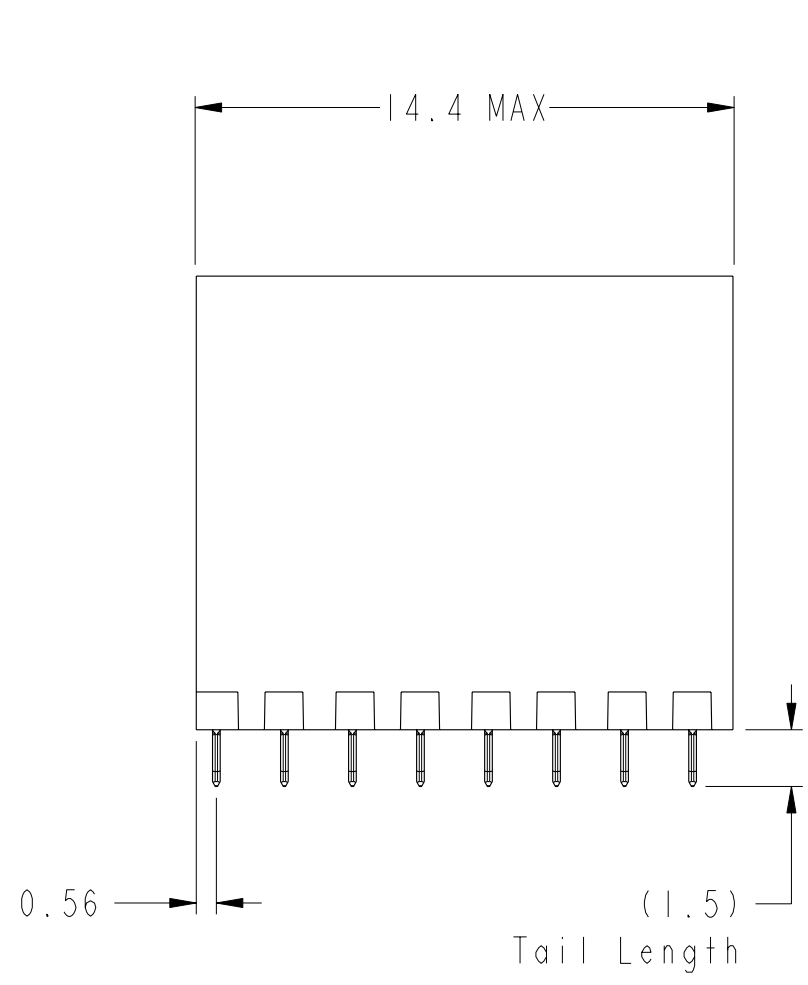

Copyright FCI.

spec ref	-	dr	Sandar Soe	2014/05/16	projection	mm	size	A2	scale	1:1	
tolerance std	ISO 406 ISO 1101	eng	Sandar Soe	2015/10/30		mm	ecn no	ELX-S-18192-1	rel level	Released	
TOLERANCES UNLESS OTHERWISE SPECIFIED		chr	-	appr							Chen-Hong Tan
surface	ISO 1302	linear	0.X	±0.3		title MODULE ASSEMBLY, XCEDE HD Vertical Header, 4 Pair 8 Column	dwg no 10130104	rev B	Product - Customer Drw		
		angular	0°	±2°					cat. no.	-	sheet 2 of 8
									www.fci.com		

PDS: Rev :B

STATUS:Released

Printed: Nov 03, 2015

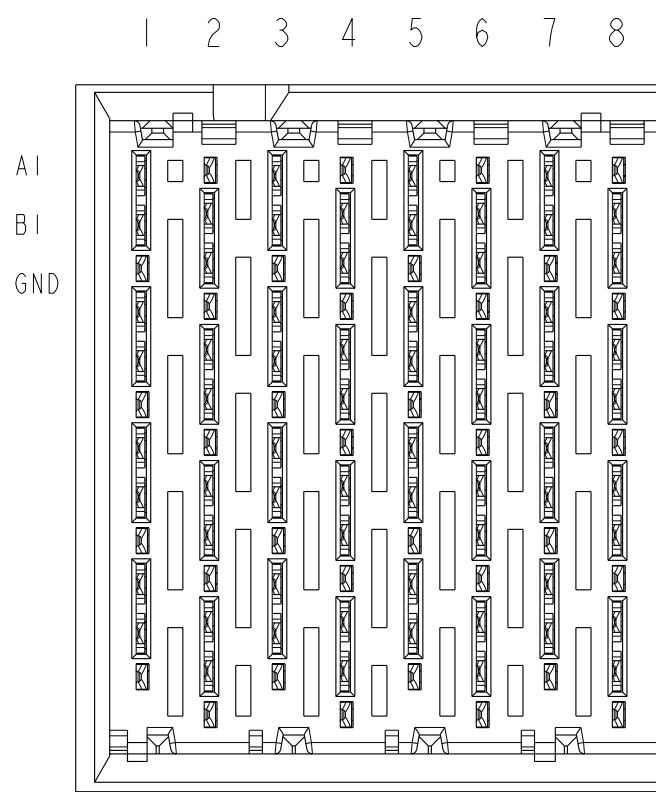

LEFT WALL MODULE

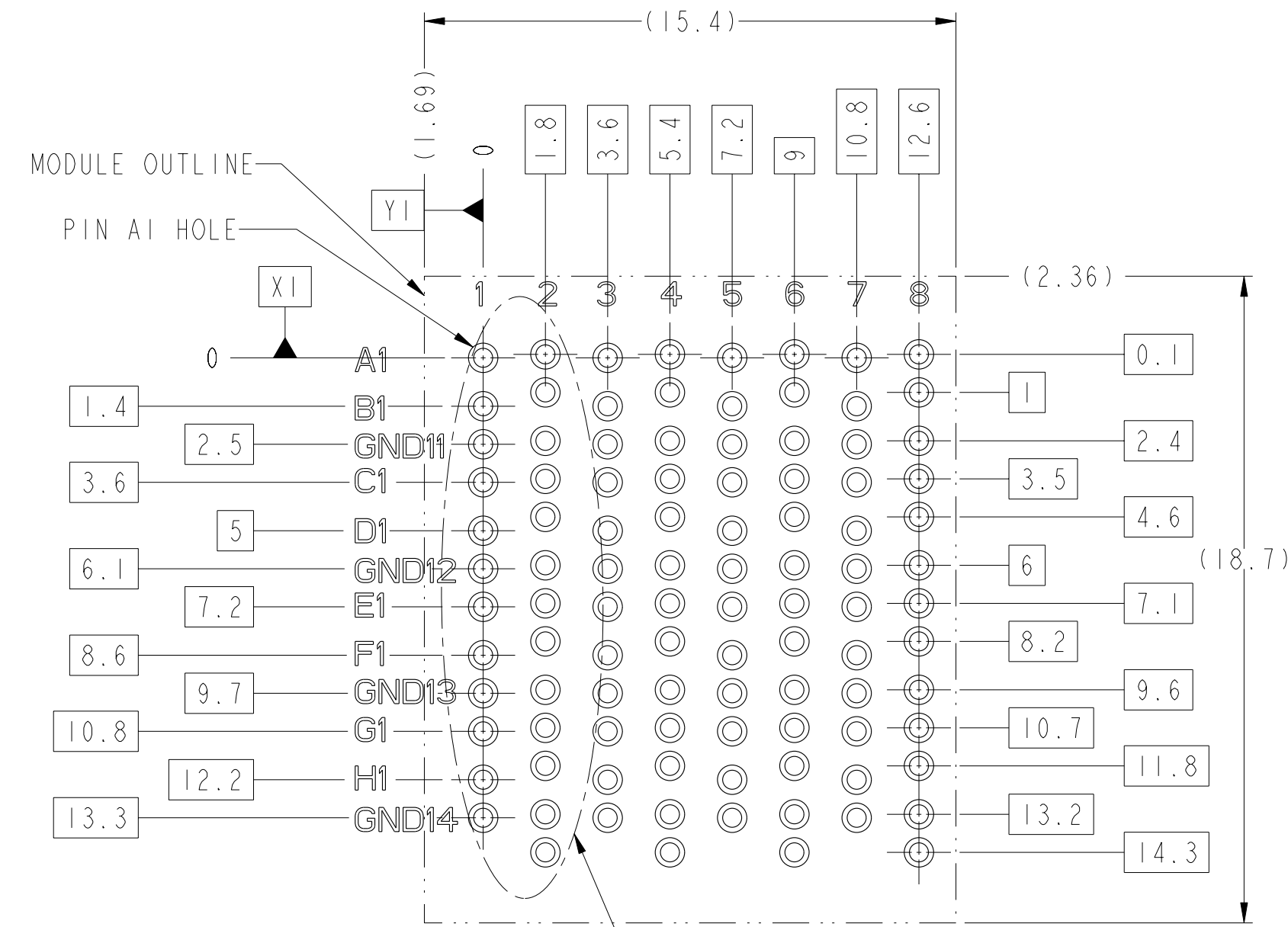
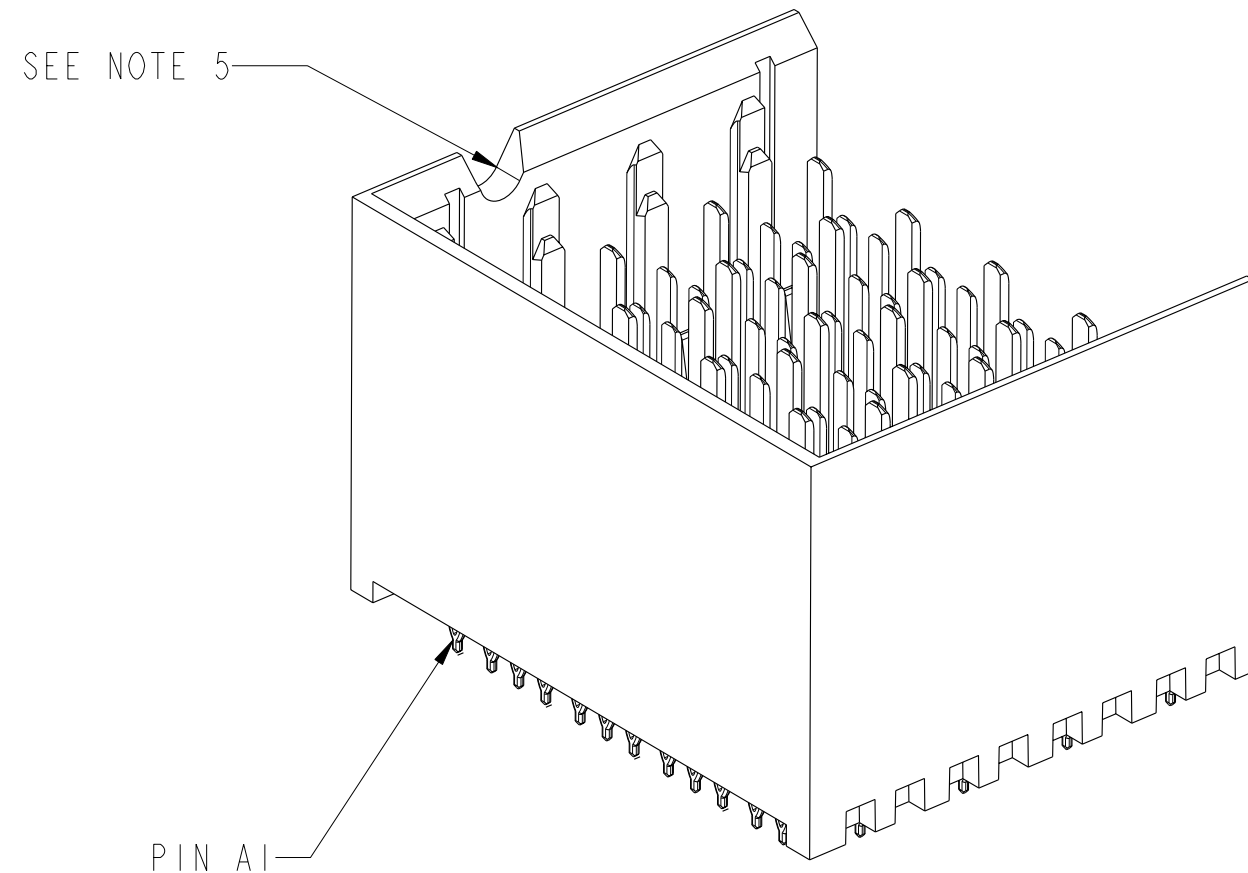

SEE DETAIL A
On Sheet 8 For Details

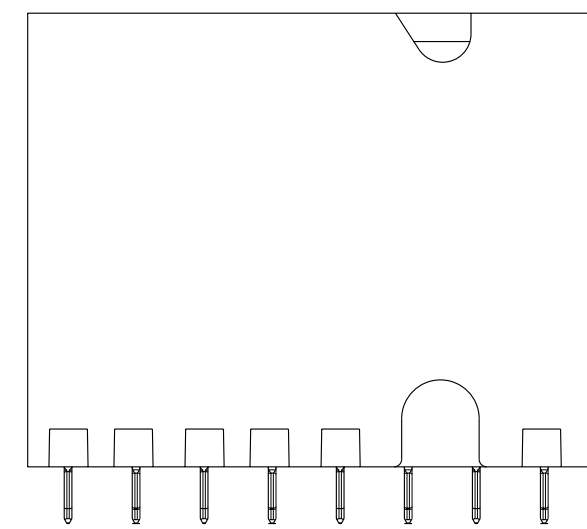
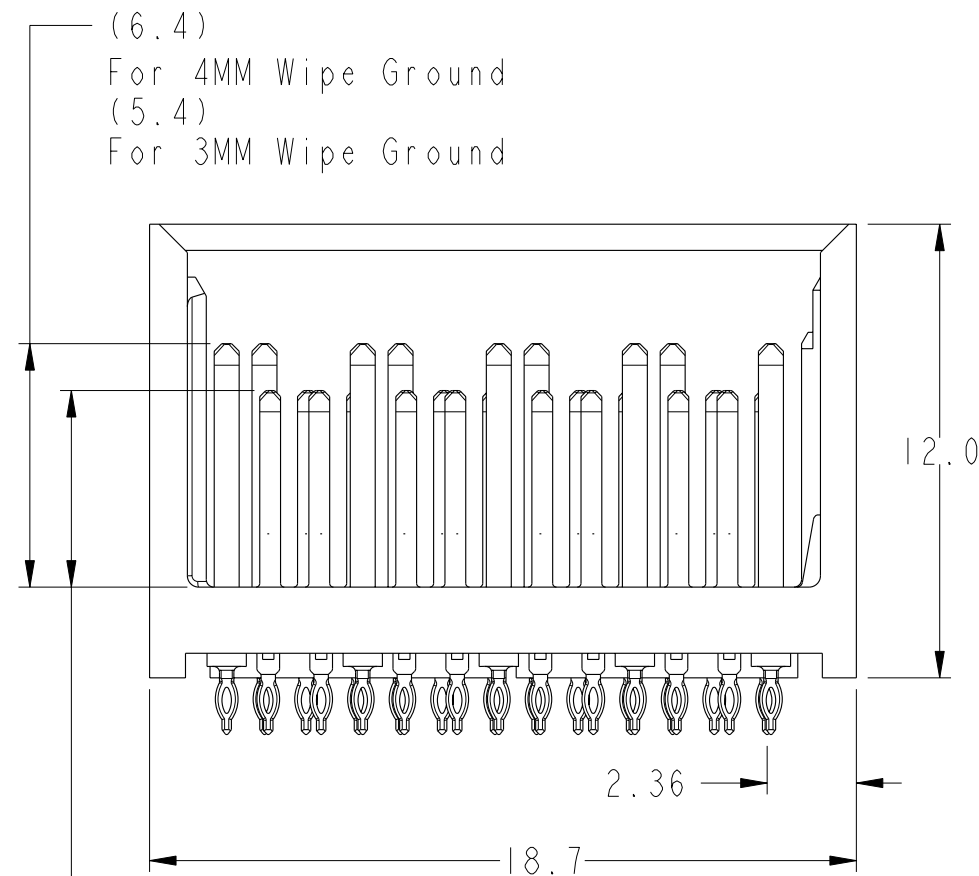
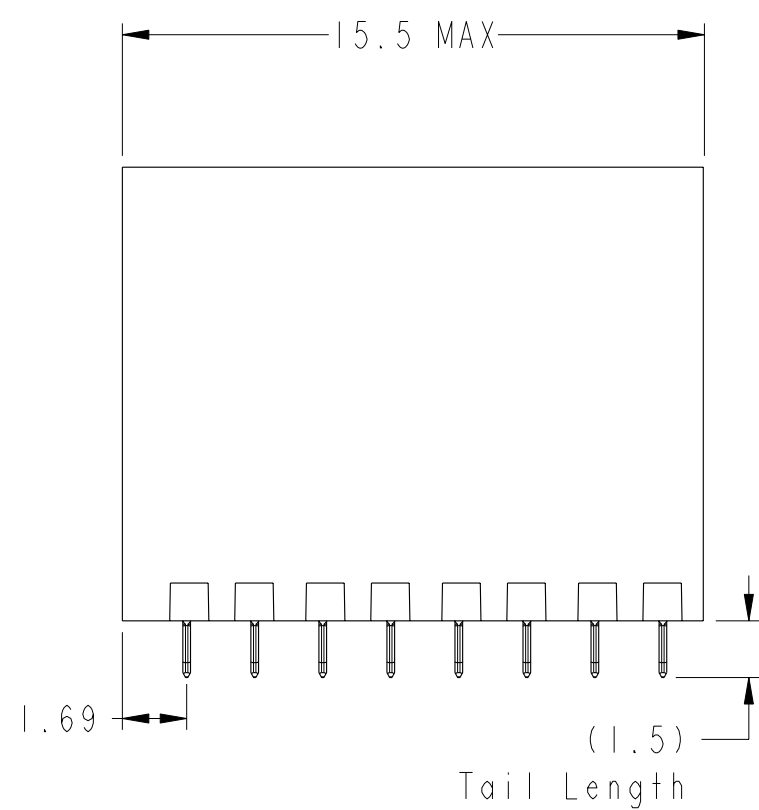

BP HOLE PATTERN COMPONENT SIDE
LEFT WALL MODULE BACKPLANE FOOTPRINT



Copyright FCI.

spec ref	-	dr	Sandar Soe	2014/05/16	projection	mm	size	A2	scale	1:1	
tolerance std	ISO 406 ISO 1101	eng	Sandar Soe	2015/10/30		mm	ecn no	ELX-S-18192-1	rel level	Released	
TOLERANCES UNLESS OTHERWISE SPECIFIED		chr	-	appr							Chen-Hong Tan
surface	ISO 1302	linear	0.X	±0.3			MODULE ASSEMBLY, XCEDE HD Vertical Header, 4 Pair 8 Column		dwg no	10130104	
		angular	0°	±2°	www.fci.com	cat. no.	-	Product - Customer Drw	sheet 3 of 8	rev	B

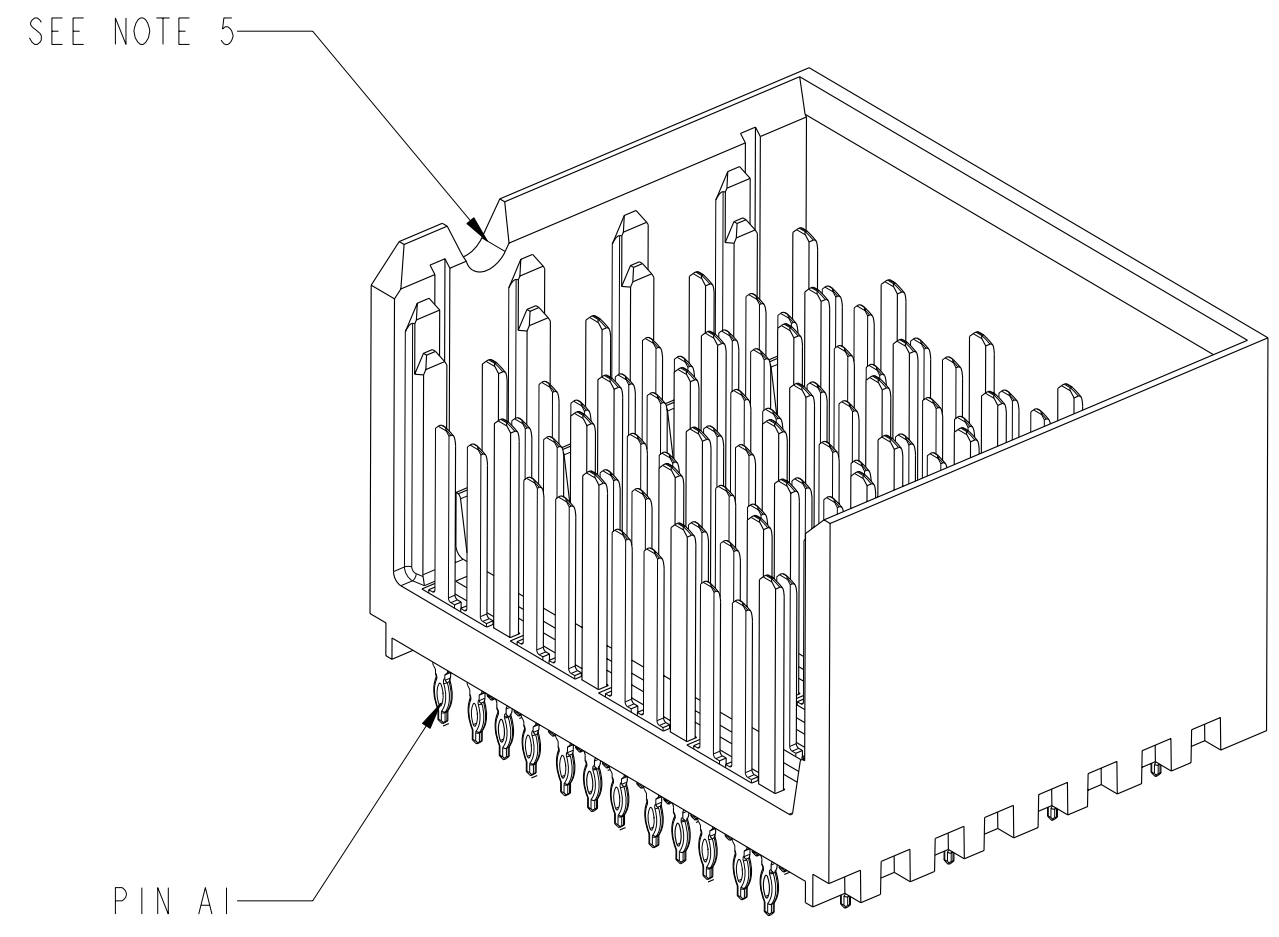
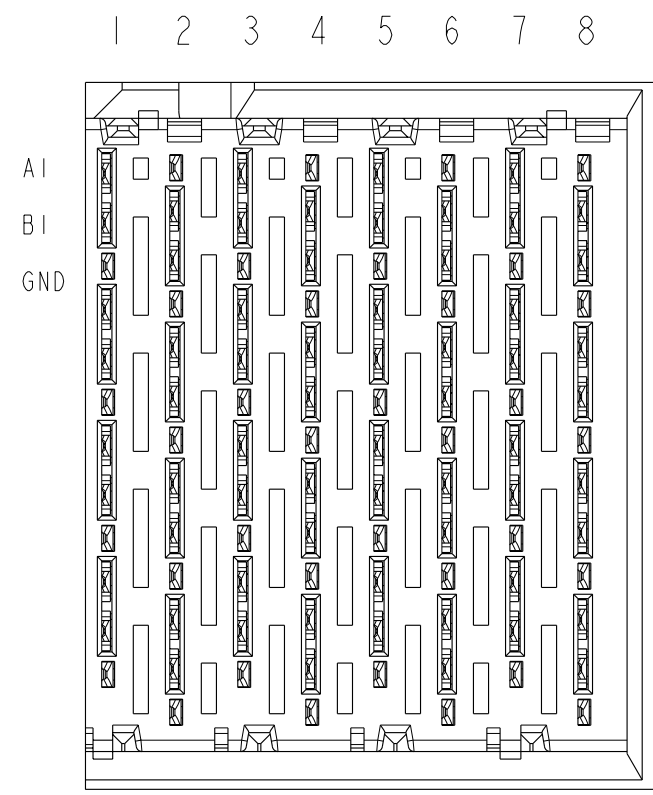

RIGHT WALL MODULE

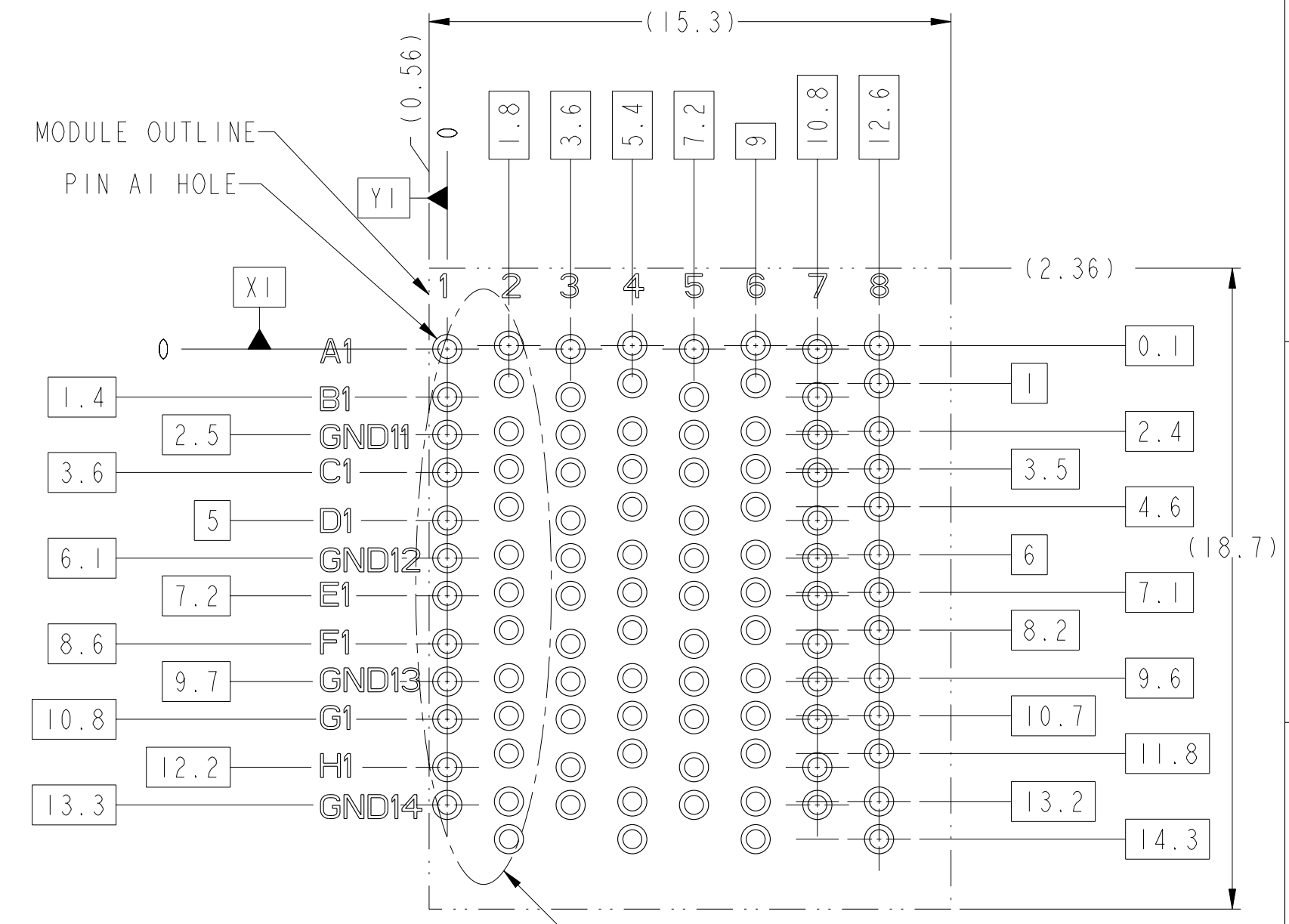

SEE DETAIL A
On Sheet 8 For Details

BP HOLE PATTERN COMPONENT SIDE

RIGHT WALL MODULE BACKPLANE FOOTPRINT

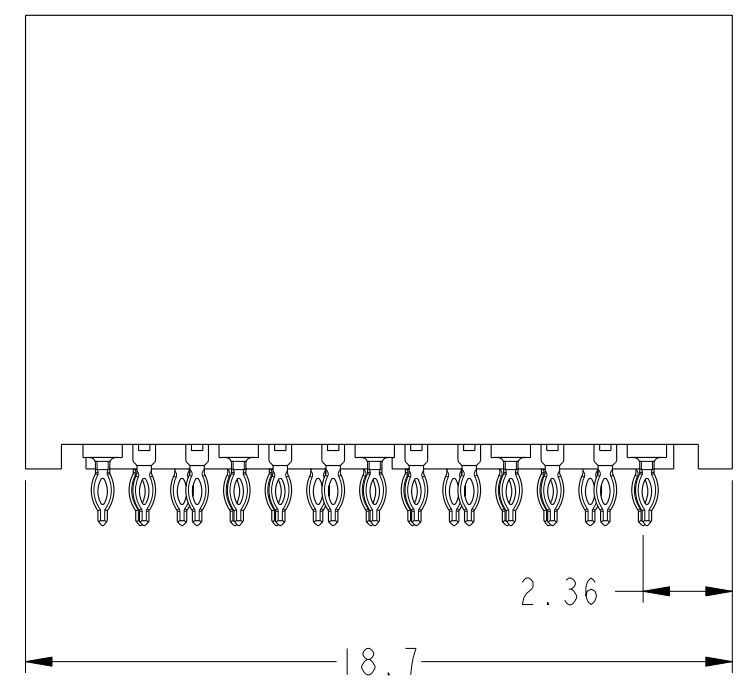
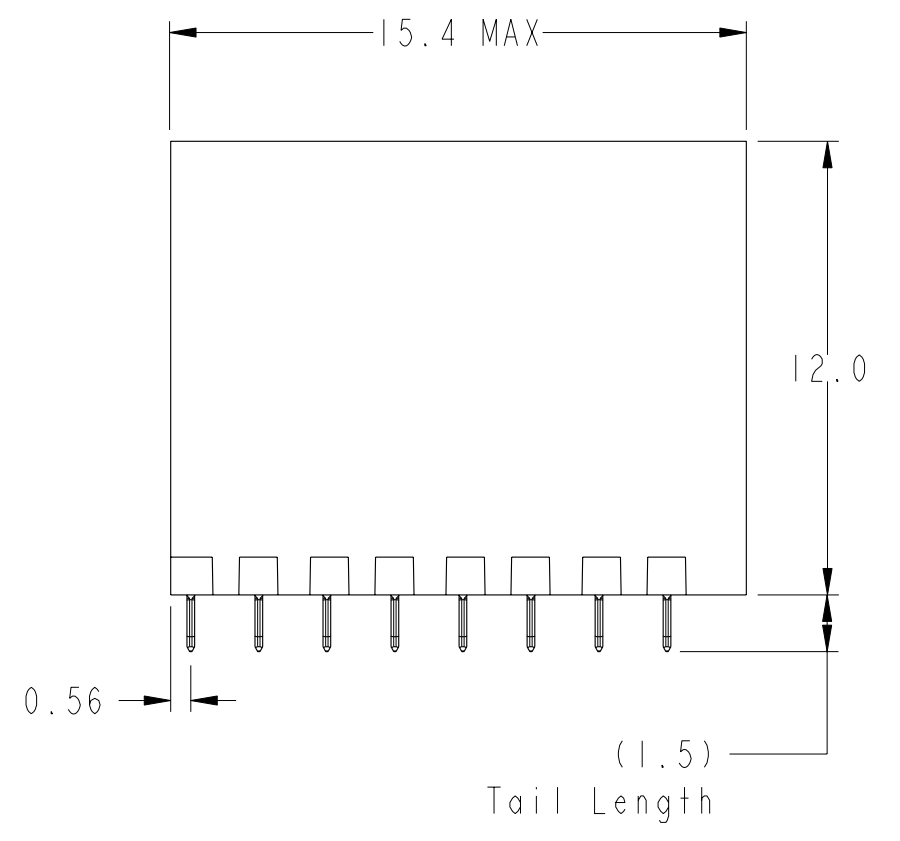
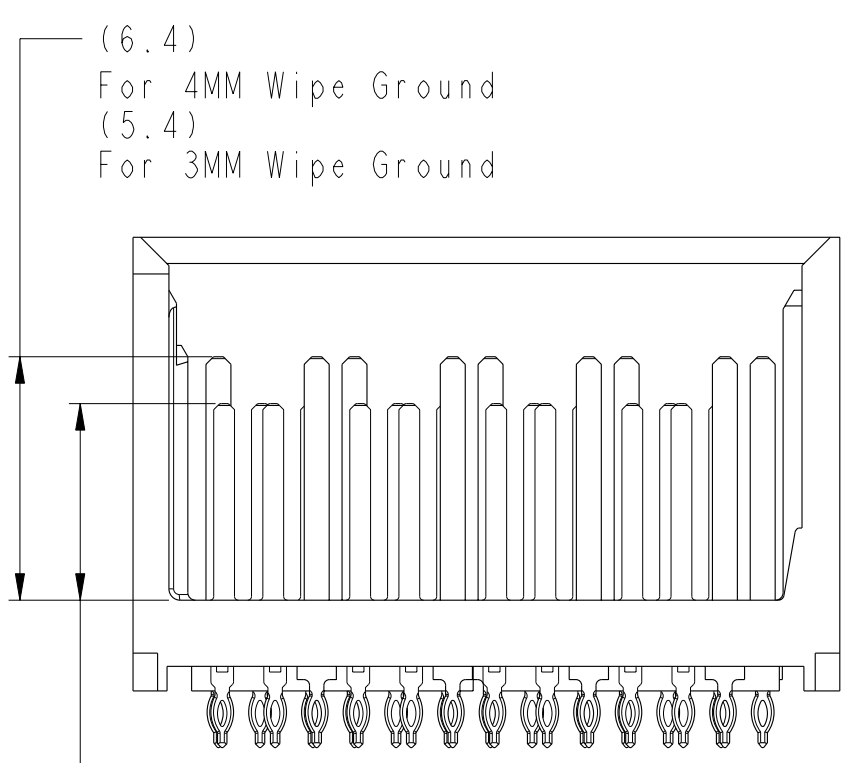

Copyright FCI.

spec ref	-	dr	Sander Soe	2014/05/16	projection	mm	size	A2	scale	1:1	
tolerance std	ISO 406 ISO 1101	eng	Sander Soe	2015/10/30		mm	ecn no	ELX-S-18192-1	rel level	Released	
TOLERANCES UNLESS OTHERWISE SPECIFIED		chr	-	apppr							Chen-Hong Tan
surface	ISO 1302	linear	0.X	±0.3			title	MODULE ASSEMBLY, XCEDE HD		dwg no 10130104	rev B
			0.XX	±0.10	www.fci.com	cat. no.	Product - Customer Drw		sheet 4 of 8		
		angular	0°	±2°	PDS: Rev :B		STATUS:Released		Printed: Nov 03, 2015		

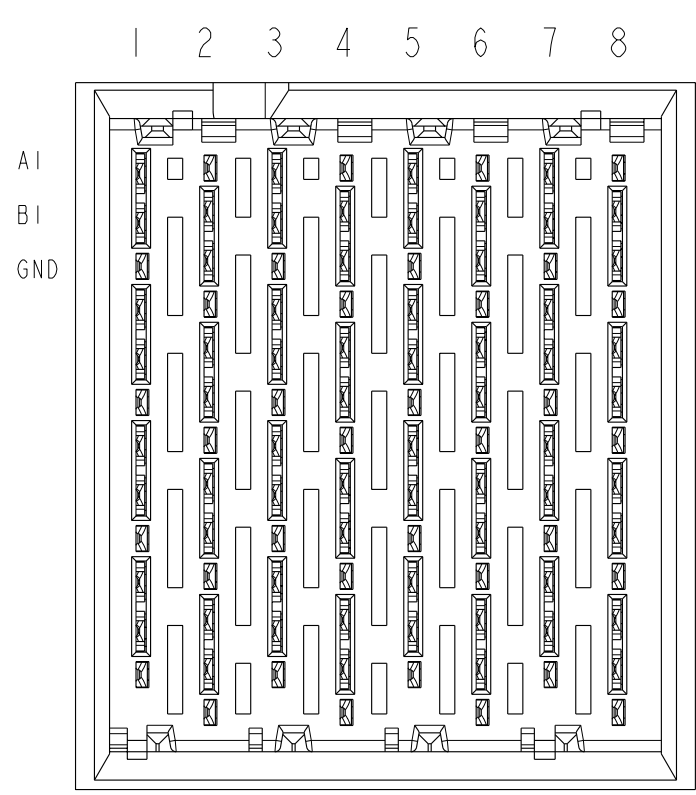

FOUR WALL MODULE

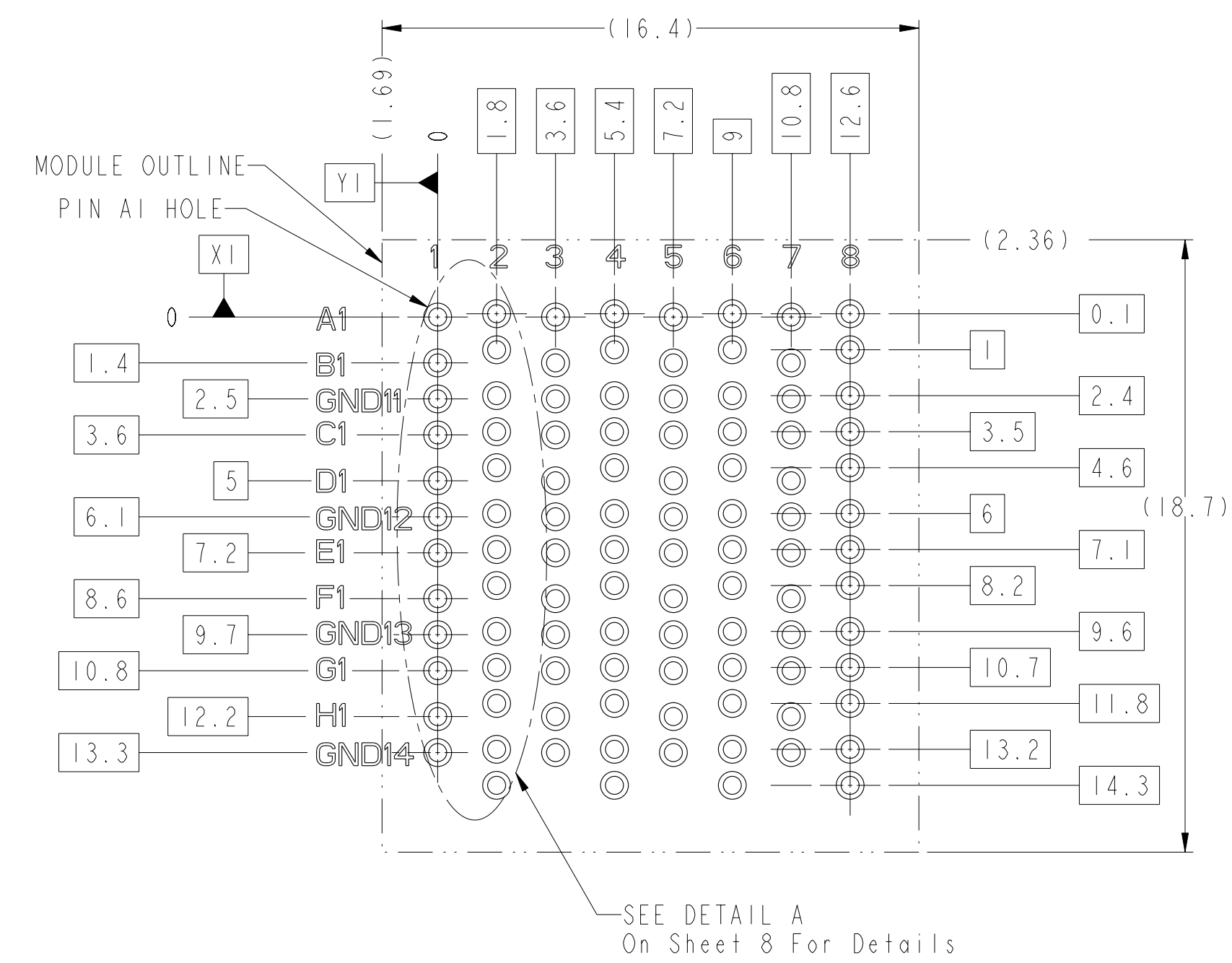
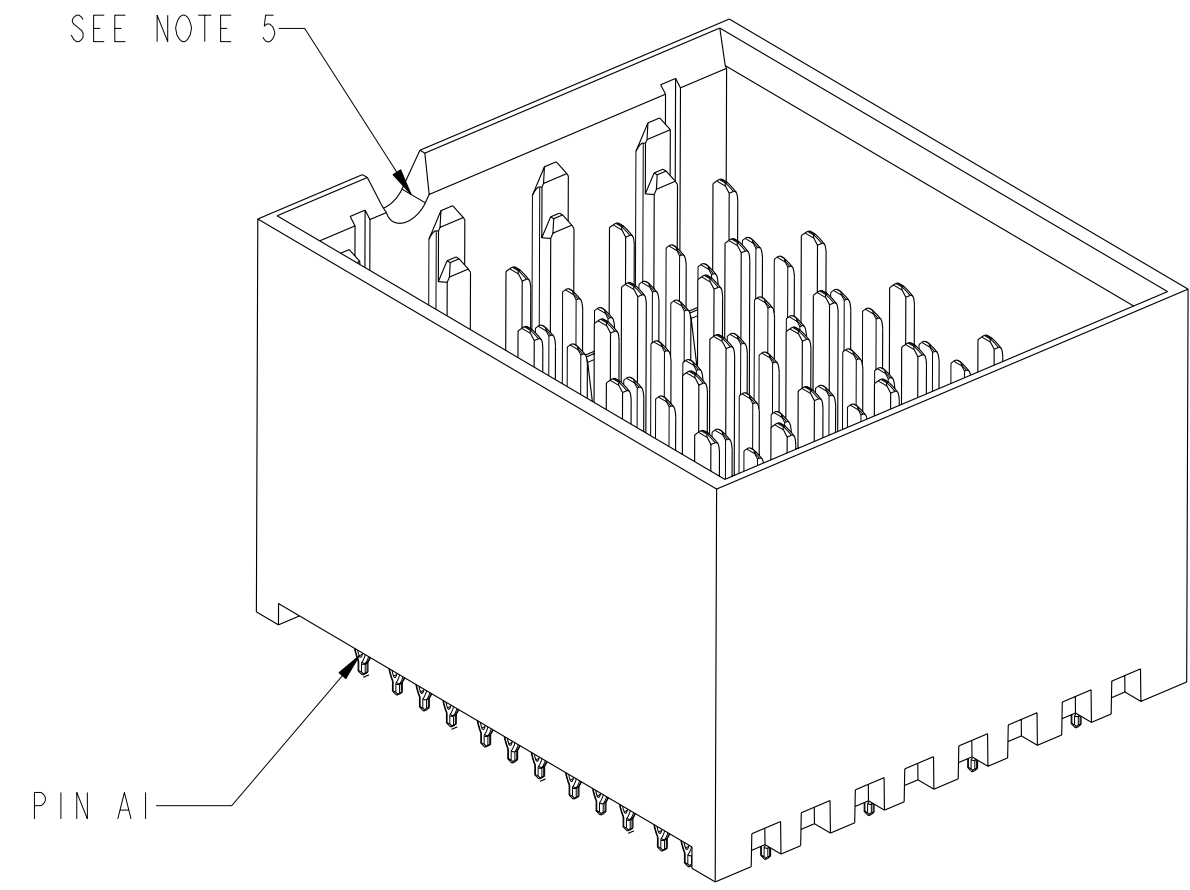

BP HOLE PATTERN COMPONENT SIDE

FOUR WALL MODULE BACKPLANE FOOTPRINT

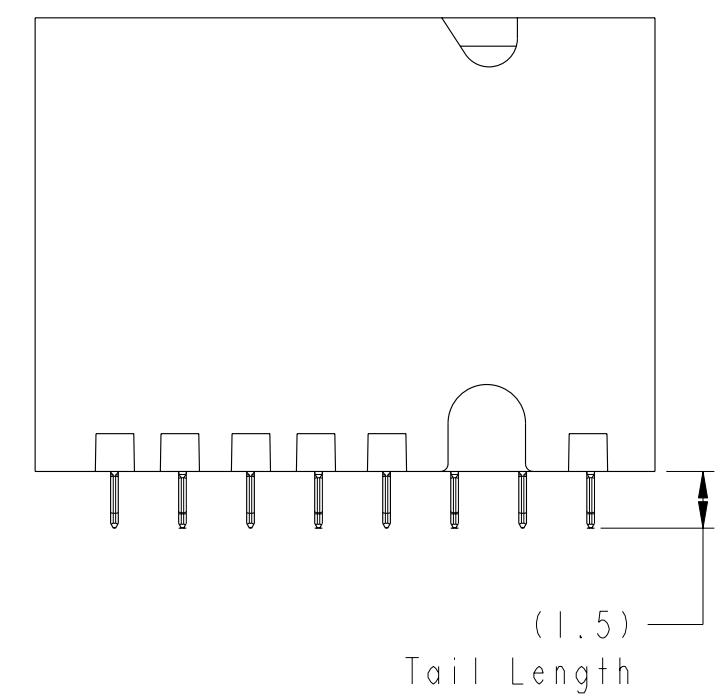
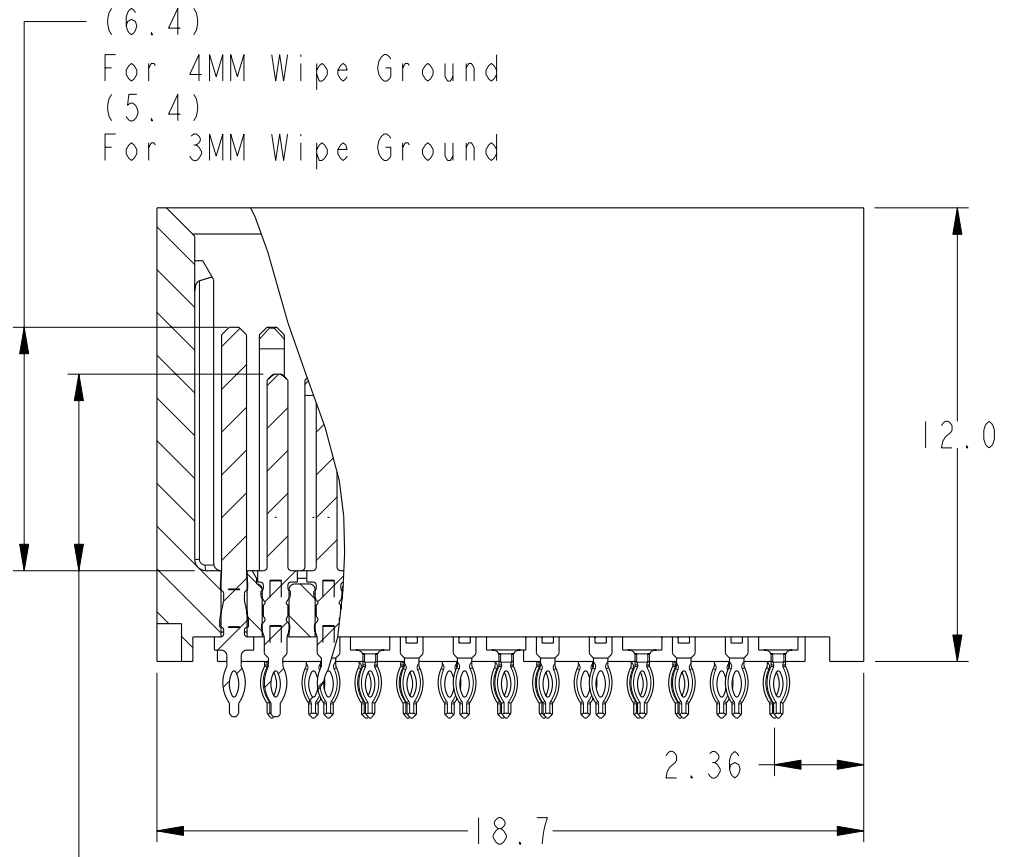
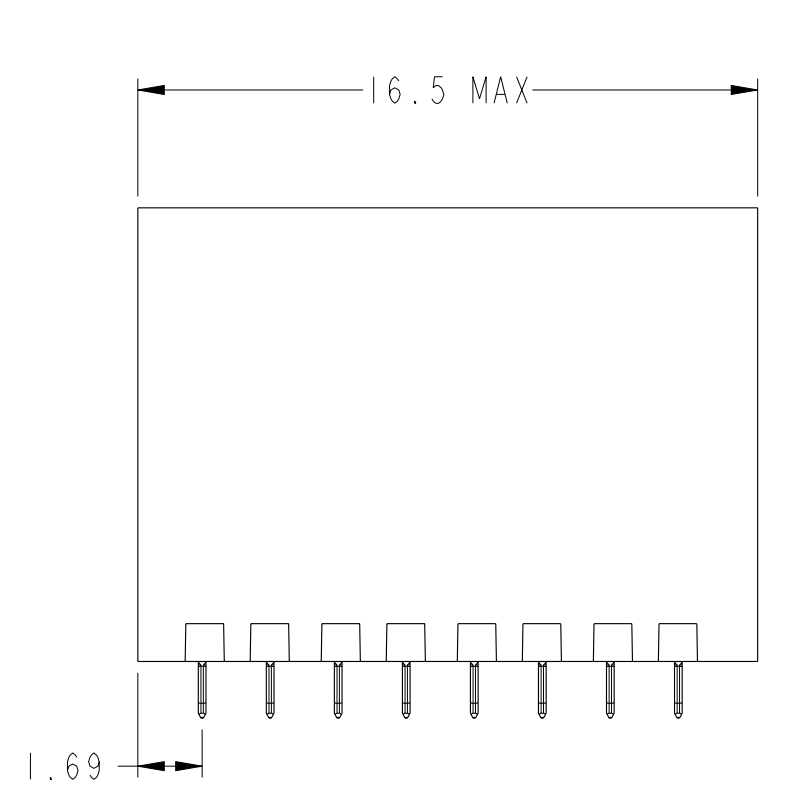

spec ref	-	dr	Sandar Soe	2014/05/16	projection	mm	size	A2	scale	1:1	
tolerance std	ISO 406 ISO 1101	eng	Sandar Soe	2015/10/30		mm	ecn no	ELX-S-18192-1	rel level	Released	
TOLERANCES UNLESS OTHERWISE SPECIFIED		chr	-	appr							Chen-Hong Tan
surface	ISO 1302	linear	0.X	±0.3		TITLE MODULE ASSEMBLY, XCEDE HD Vertical Header, 4 Pair 8 Column	dwg no 10130104	rev B	Product - Customer Drw		
		angular	0°	±2°					cat. no.	-	sheet 5 of 8
									www.fci.com		

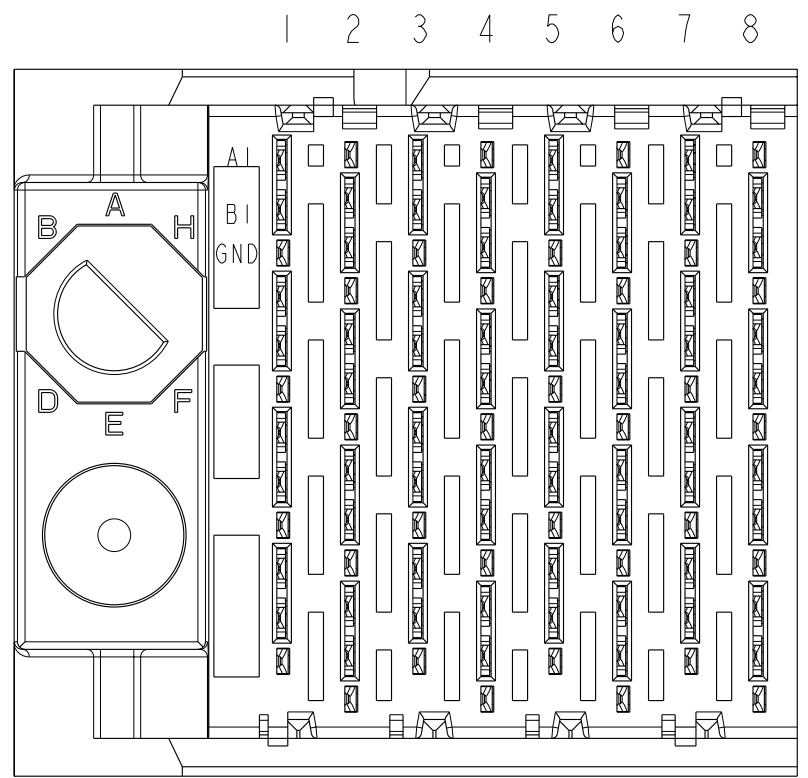

LEFT POLARIZING/GUIDE MODULE

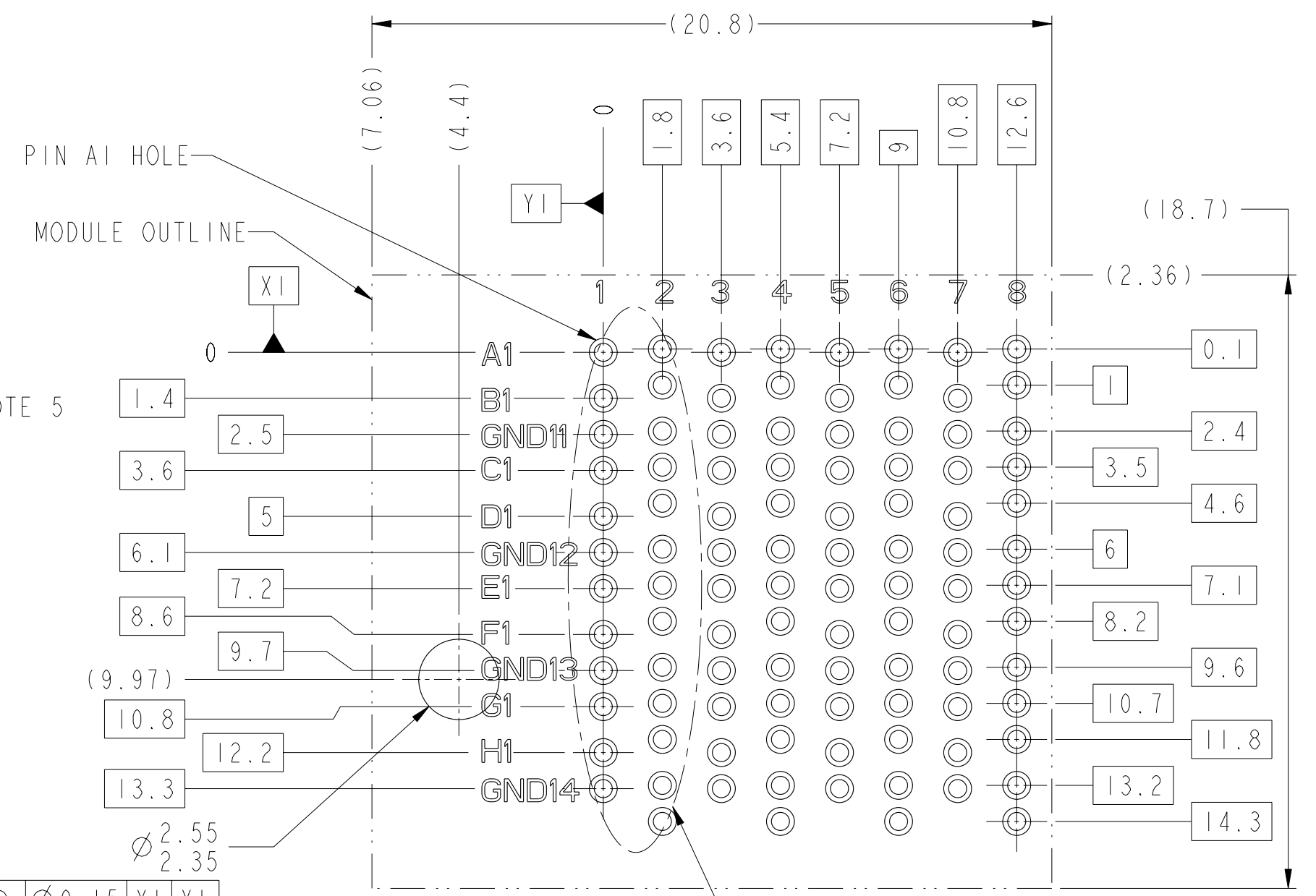
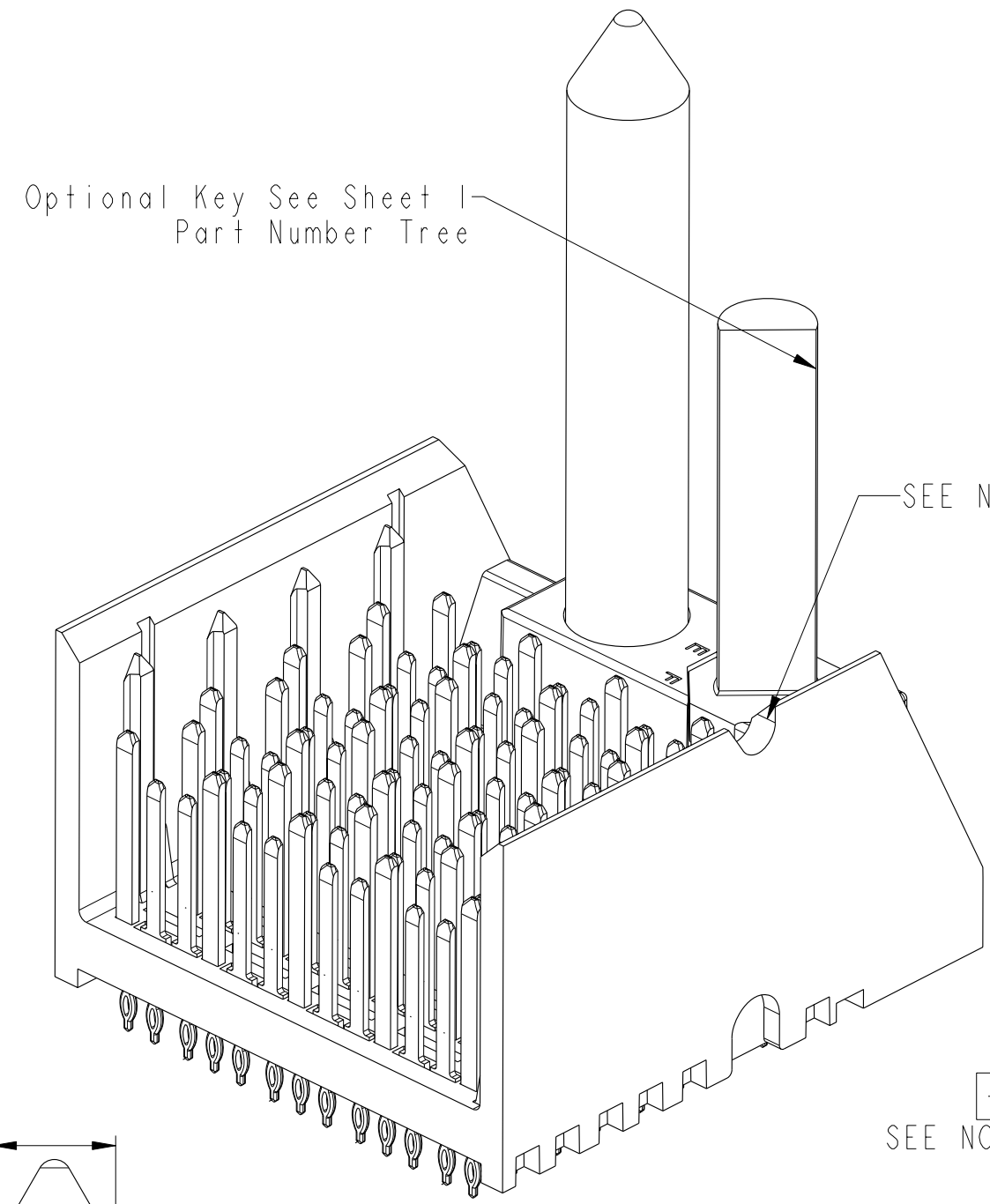

SEE NOTE 11 & TABLE 1

SEE DETAIL A OnSheet 8 For Details

BP HOLE PATTERN COMPONENT SIDE
LEFT POLARIZING GUIDE MODULE
BACKPLANE FOOTPRINT

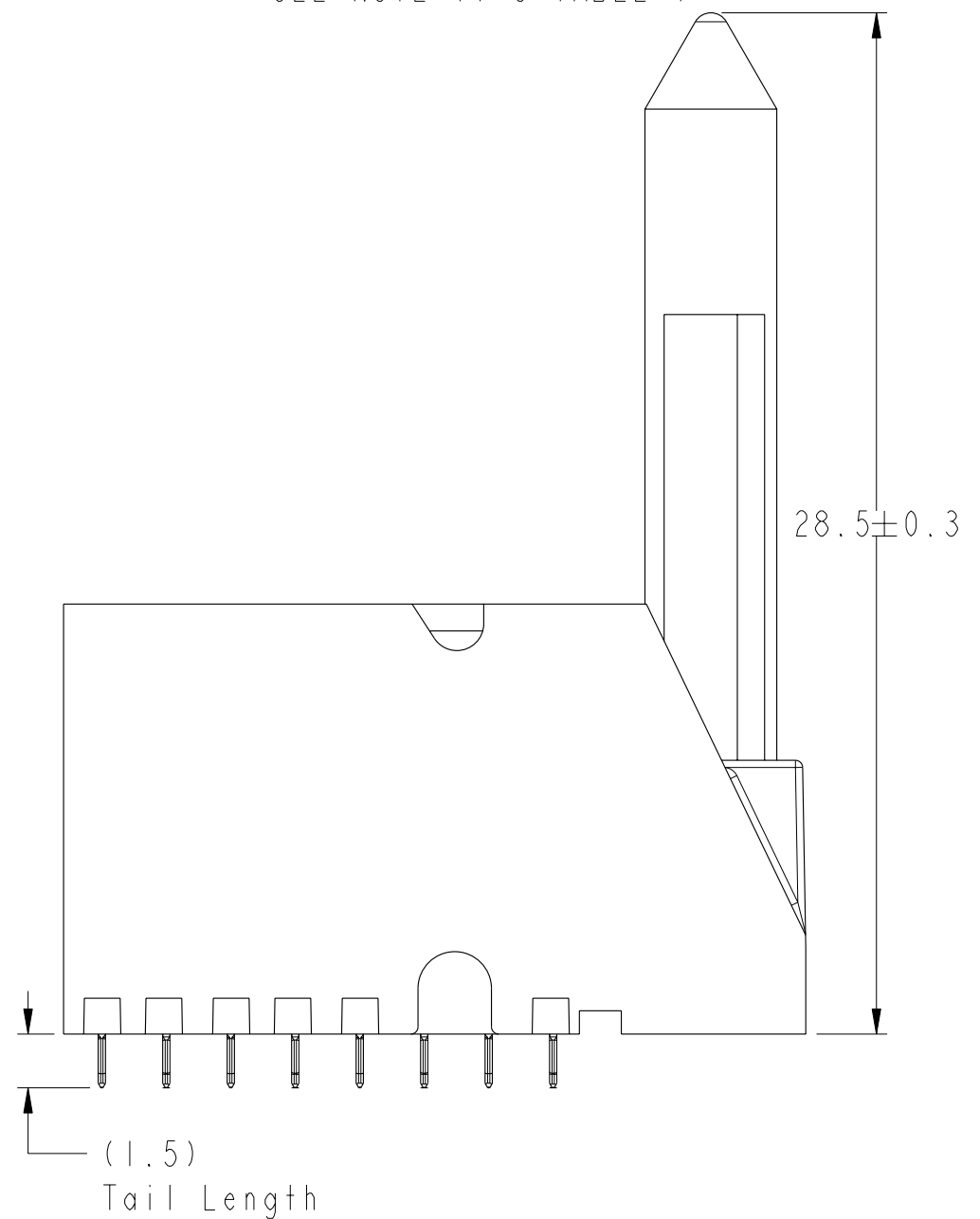
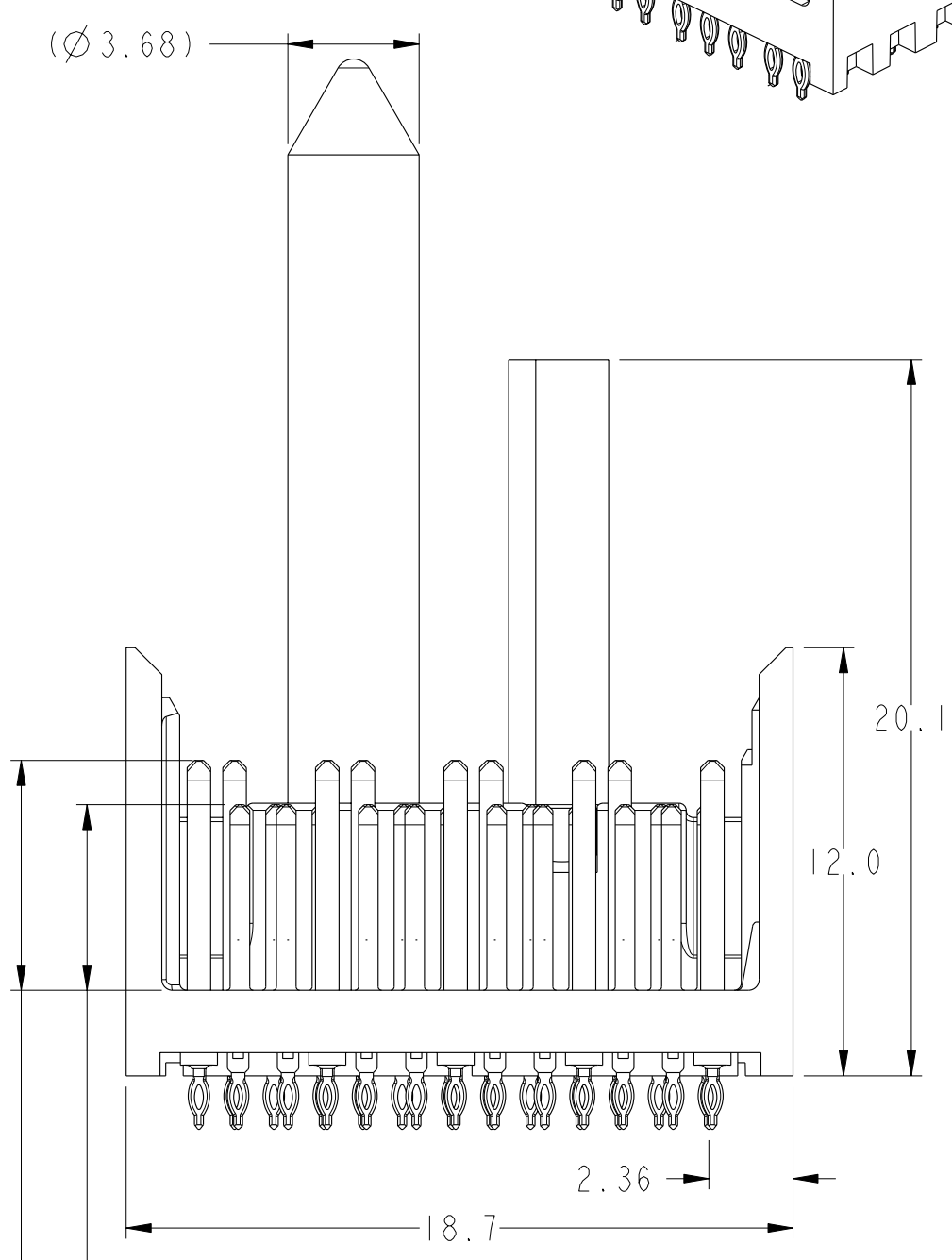
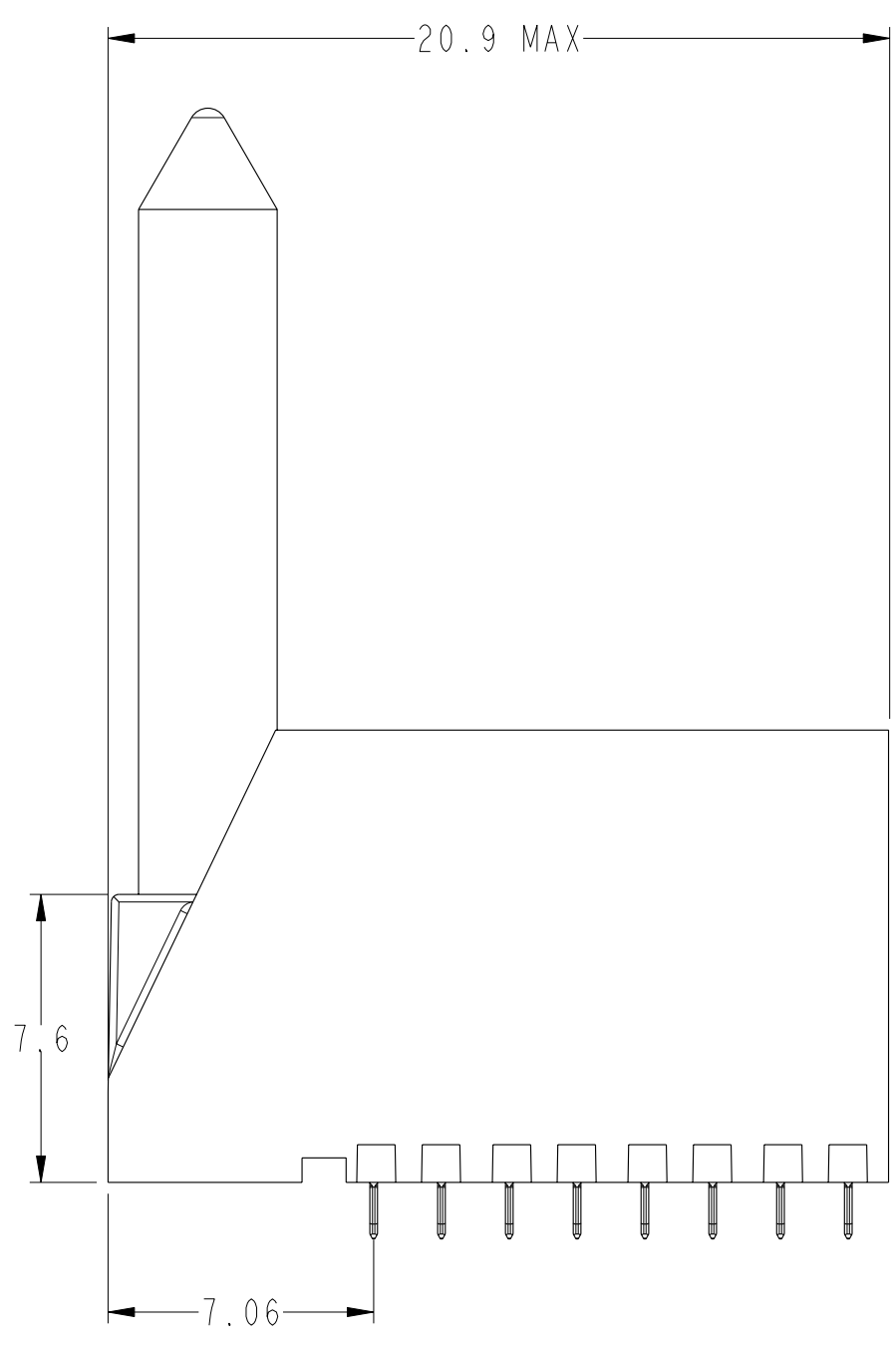

(5.2) For 3MM Wipe Signal
(4.2) For 2MM Wipe Signal
(6.4) For 4MM Wipe Ground
(5.4) For 3MM Wipe Ground

spec ref	-	dr	Sander Soe	2014/05/16	projection	mm	size	A2	scale	1:1
tolerance std	ISO 406 ISO 1101	eng	Sander Soe	2015/10/30		mm	ecn no	ELX-S-18192-1	rel level	Released
TOLERANCES UNLESS OTHERWISE SPECIFIED		chr	-	apppr						
surface	ISO 1302	linear	0.X	±0.3			title	MODULE ASSEMBLY, XCEDE HD		cat. no. - Product - Customer Drw sheet 6 of 8
		angular	0°	±2°	www.fci.com	Veritcal Header, 4 Pair 8 Column 10130104 rev B				

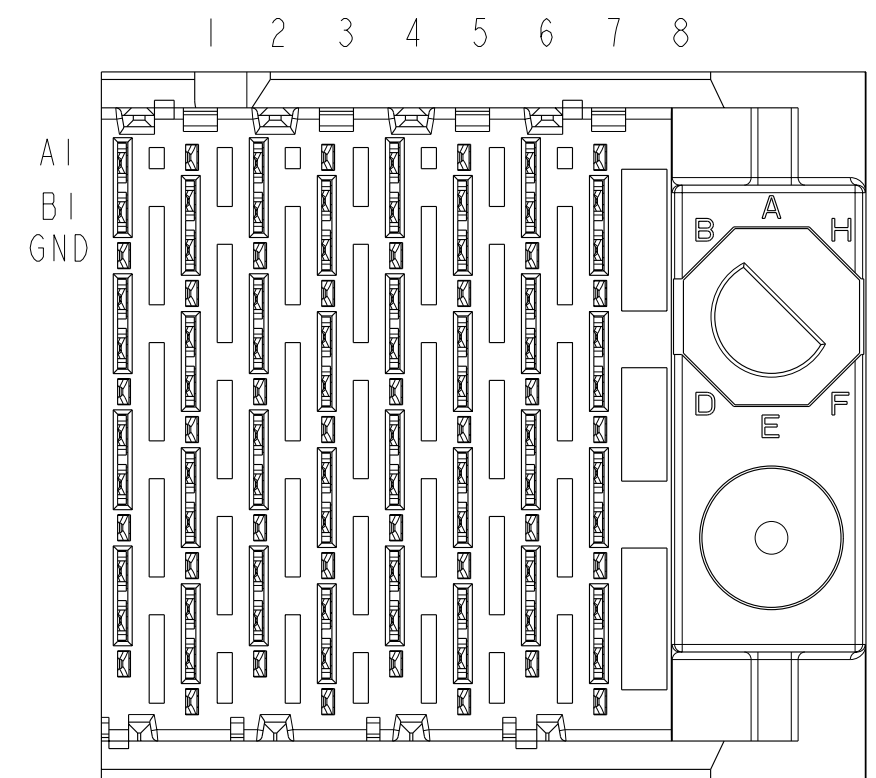

Optional Key See Sheet 1
Part Number Tree

SEE NOTE 5

PIN AI

RIGHT POLARIZING/GUIDE MOUDLE

MOUDLE OUTLINE
PIN AI HOLE

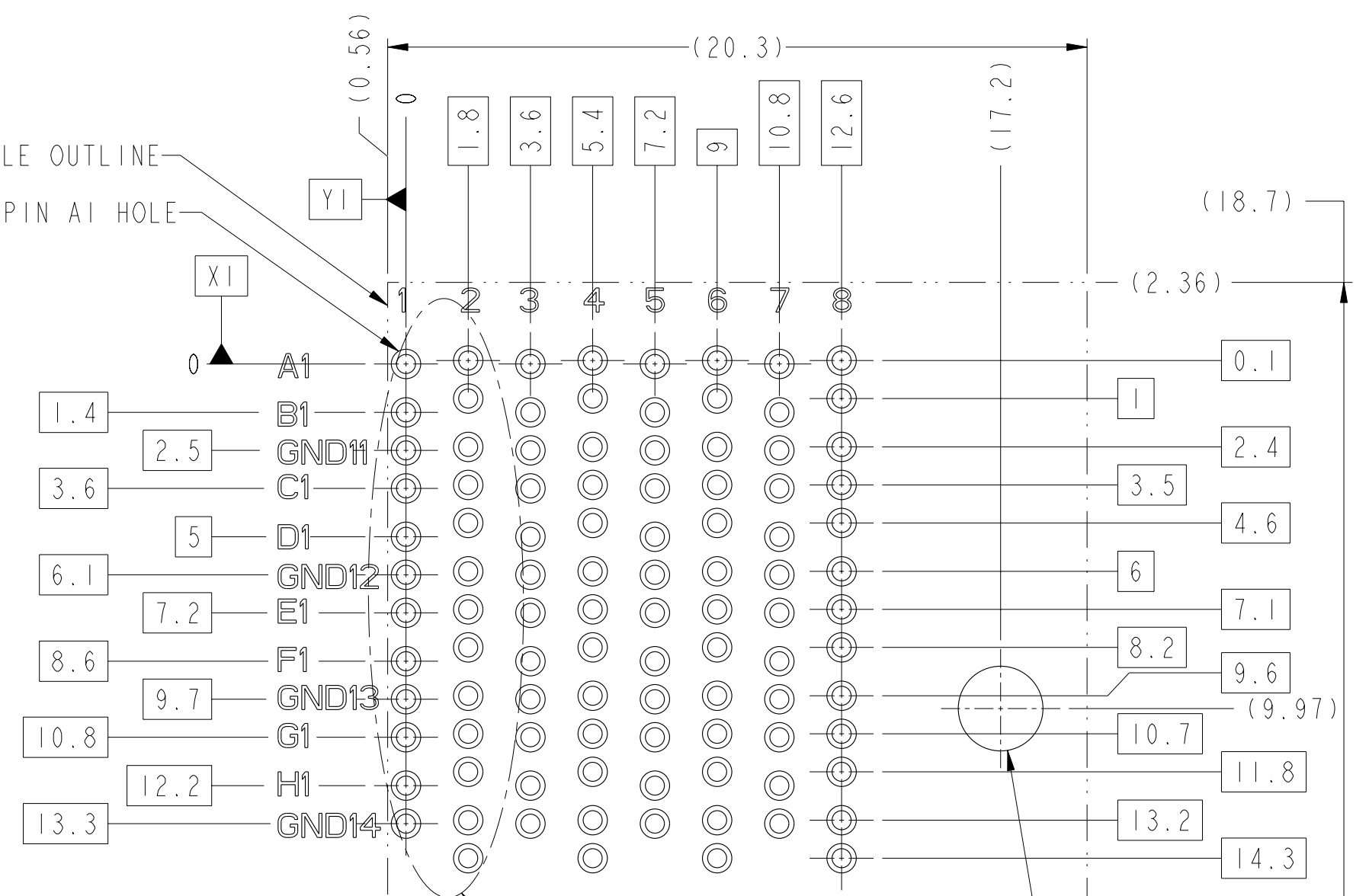

SEE DETAIL A
On Sheet 8 For Details

⊕ ∅0.15 XI YI
SEE NOTE 11 &
TABLE 1

BP HOLE PATTERN COMPONENT SIDE
RIGHT POLAIZING/GUIDE MODULE
BACKPLANE FOOTPRINT

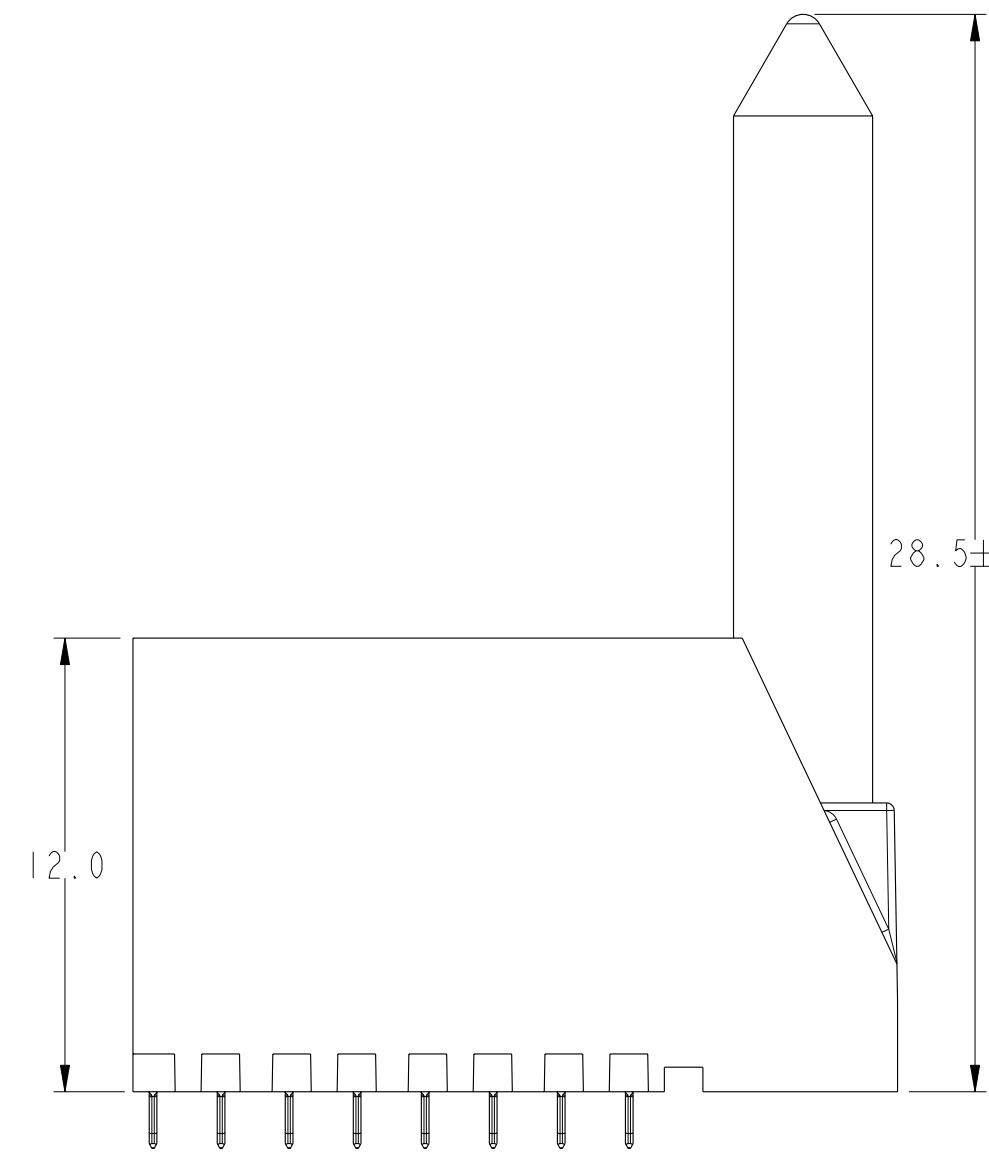
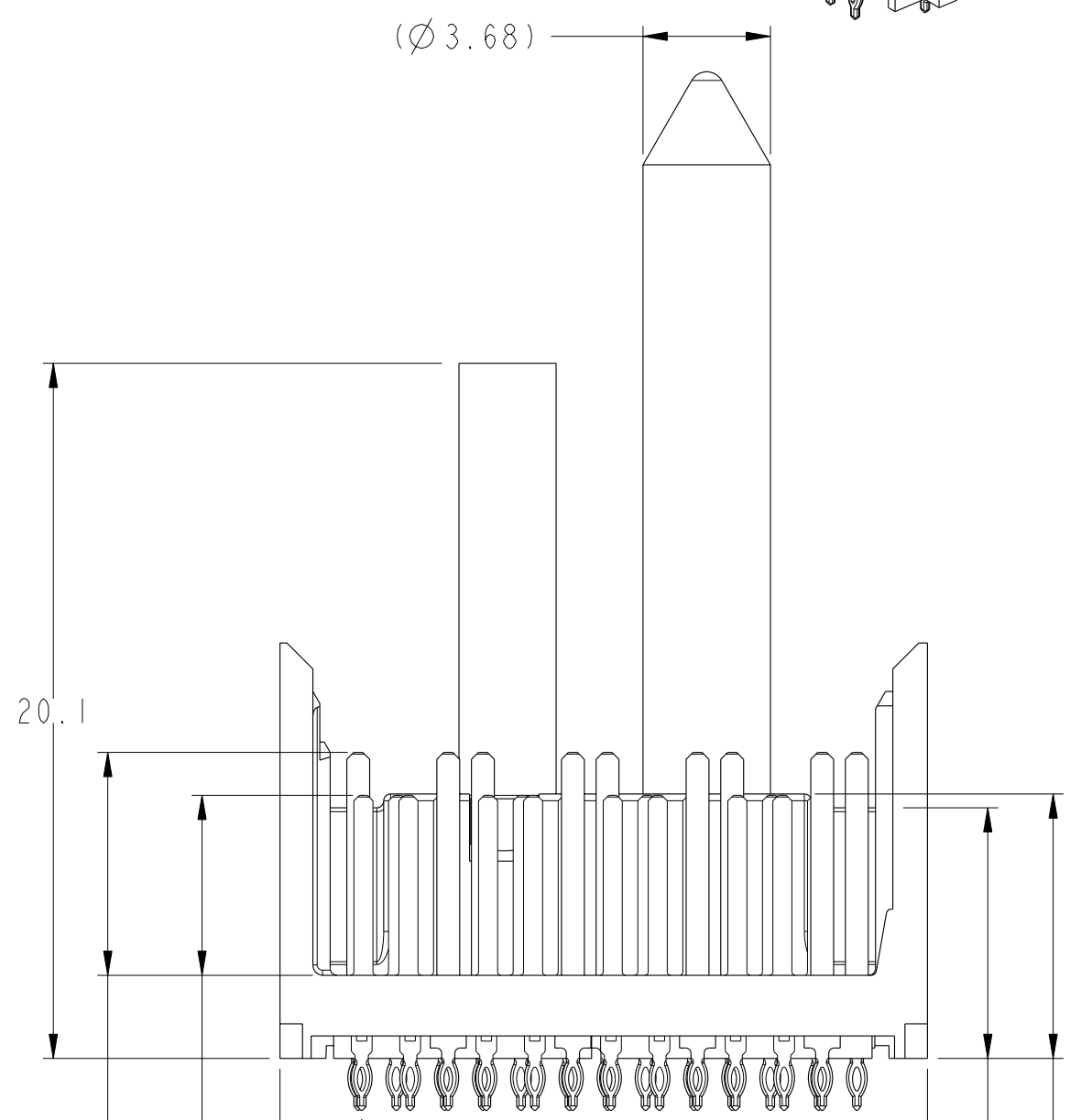
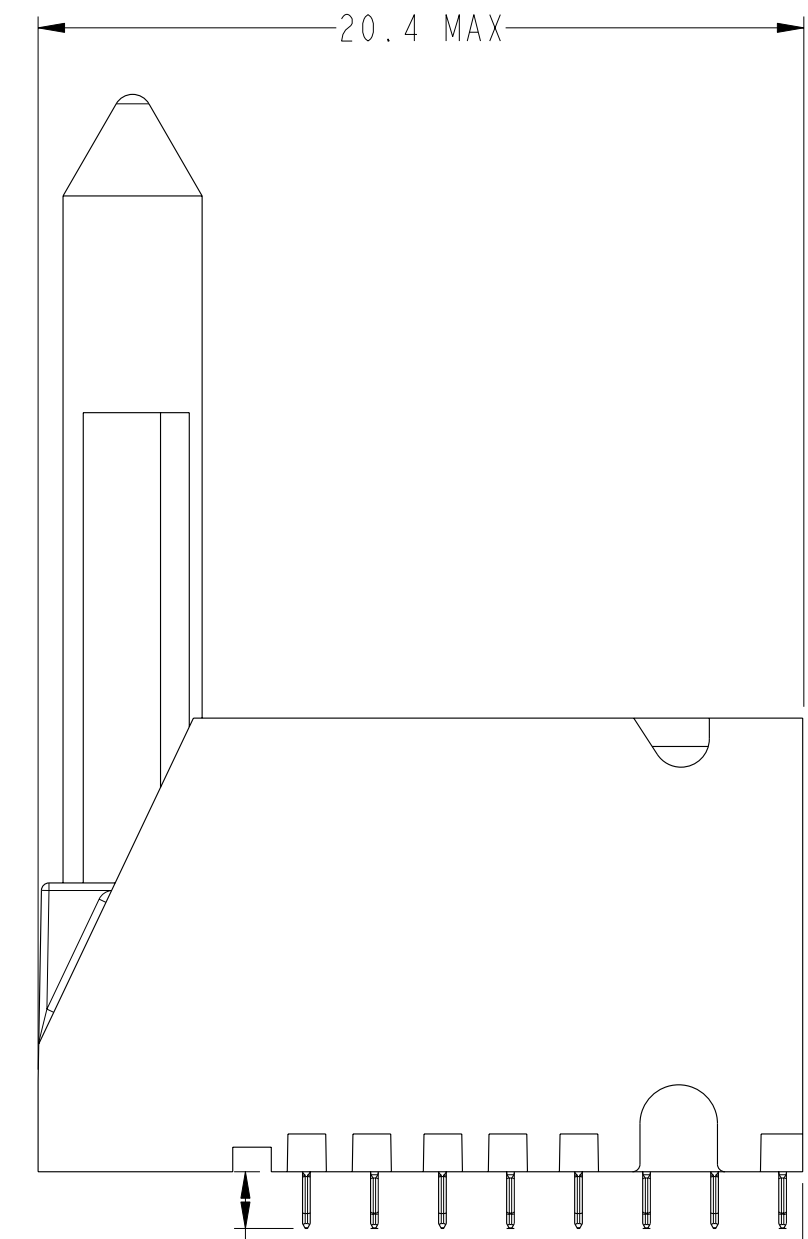

(5.2)
For 3MM Wipe Signal
(4.2)
For 2MM Wipe Signal
(6.4)
For 4MM Wipe Ground
(5.4)
For 3MM Wipe Ground

spec ref	-	dr	Sandar Soe	2014/05/16	projection	mm	size	A2	scale	1:1
tolerance std	ISO 406 ISO 1101	eng	Sandar Soe	2015/10/30	chr	-	ecn no	ELX-S-18192-1	rel level	Released
surface	ISO 1302	appr	Chen-Hong Tan	2015/11/02	product family	-	rel level	Released	cat. no.	-
linear	0.X ±0.3 0.XX ±0.10 0.XXX ±0.05	angular	0° ±2°			MODULE ASSEMBLY, XCEDE HD Vertical Header, 4 Pair 8 Column	dwg no 10130104	rev B	Product - Customer Drw sheet 7 of 8	

TABLE 3		
	COMPLIANT PIN DRILL $\varnothing 0.55 [0.0217"]$	COMPLIANT PIN DRILL $\varnothing 0.45 [0.0177"]$
PTH	$\varnothing 0.45 \pm 0.05$	$\varnothing 0.36 \pm 0.05$
DRILL	$\varnothing 0.55 [0.0217"]$	$\varnothing 0.45 [0.0177"]$
PAD	$\varnothing 0.85$	$\varnothing 0.75$

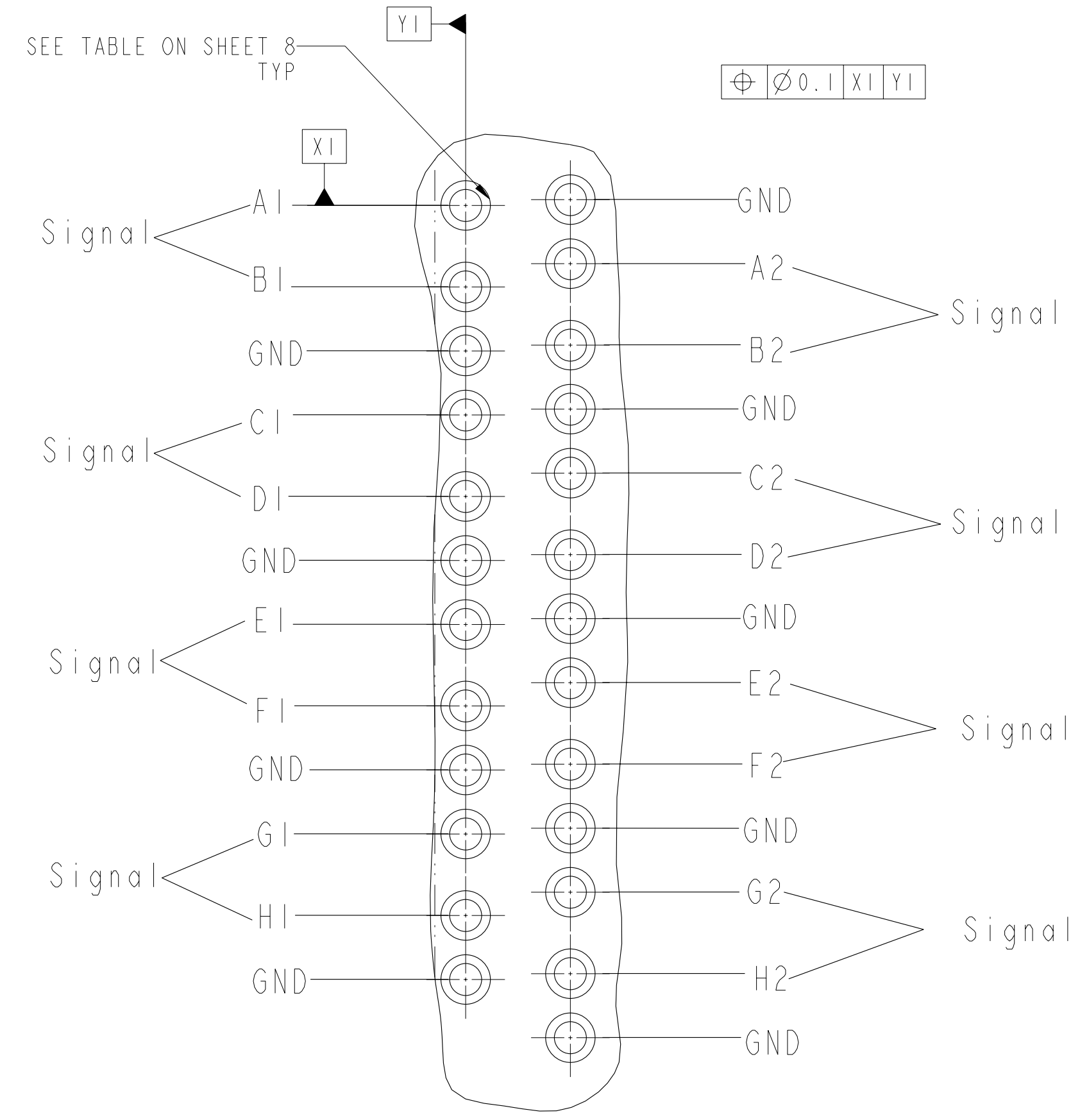

DETAIL A
SCALE 12:1

NOTES:

1. CONNECTOR MATERIALS
SHROUD : HIGH-TEMP POLYMER, COLOR : BLACK, UL94V-0
CONTACTS : HIGH PERFORMANCE COPPER ALLOY
2. CONTACT PLATING:

SEPARABLE INTERFACE: PERFORMANCE-BASED PLATING, QUALIFIED TO MEET THE REQUIREMENTS OF FCI PRODUCT SPECIFICATION GS-12-588, INCLUDING THE TELCORDIA GR-1217-CORE (NOVEMBER 1995) CENTRAL OFFICE (CO) TEST SEQUENCE AS NOTED IN P/N TREE.

PRESS-FIT TAILS: TIN OVER NICKEL (LF) OR TIN-LEAD ALLOY OVER NICKEL (NON-LF). SEE P/N TREE.
3. PRODUCT SPECIFICATION : GS-12-0936
4. APPLICATION SPECIFICATION : GS-20-0348
5. NOTCH DESIGNATES "ROW A" SIDE OF CONNECTOR. NOTCH FEATURE ON OPPOSITE FOR PRODUCT MARKING.
6. PRODUCT MARKING :
PART NUMBER (10130104-X0J-XXXLF)
"FCI" AND DATE CODE (FCI P#####)
7. PACKAGING MEETS GS-14-920 LEAD-FREE LABELING SPECIFICATION.
8. GUIDE-PIN STYLE DESIGNATION ONLY APPLIES TO MODULE VERSIONS THAT REQUIRE GUIDE-PIN HARDWARE. FOR ALL NON-GUIDE-PIN VERSIONS, THE DEFAULT DASH-NUMBER DIGIT IN THAT LOCATION IS STILL "0".
9. SEE APPLICATION SPECIFICATION FOR ROUTING GUIDELINES, ADDITIONAL PTH GUIDELINES, MATED DIMENSIONS, GUIDE PIN SELECTION, ETC.
10. A $\triangle B$ SYMBOL WILL BE NEXT TO ANY DIMENSION, VIEW OR NOTE THAT HAS BEEN MODIFIED WITH THE CURRENT DRAWING REVISION.
11. OPTIONAL HOLE LOCATION FOR GROUNDED PIN OR ADDITIONAL GUIDE-PIN SUPPORT. SEE TABLE 1 SHEET 1 FOR ADDITIONAL DETAILS.
12. SCREW IS OPTIONAL AND ENGAGES WITH BOTTOM OF GUIDE PIN FROM BENEATH THE PCB FOR ADDITIONAL GUIDE-PIN SUPPORT.

Copyright FCI.

spec ref	-	dr	Sander Soe	2014/05/16	projection	mm	size	A2	scale	1:1	
tolerance std	ISO 406 ISO 1101	eng	Sander Soe	2015/10/30			ecn no	ELX-S-18192-1			
TOLERANCES UNLESS OTHERWISE SPECIFIED		chr	-	2015/11/02			rel level	Released			
surface	ISO 1302	appr	Chen-Hong Tan	2015/11/02	product family			cat. no.	10130104	rev	B
linear	0.X ±0.3 0.XX ±0.10 0.XXX ±0.05	www.fci.com		MODULE ASSEMBLY, XCEDE HD Vertical Header, 4 Pair 8 Column		Product - Customer Drw		sheet 8 of 8			
angular	0° ±2°										



Компания «ЭлектроПласт» предлагает заключение долгосрочных отношений при поставках импортных электронных компонентов на взаимовыгодных условиях!

Наши преимущества:

- Оперативные поставки широкого спектра электронных компонентов отечественного и импортного производства напрямую от производителей и с крупнейших мировых складов;
- Поставка более 17-ти миллионов наименований электронных компонентов;
- Поставка сложных, дефицитных, либо снятых с производства позиций;
- Оперативные сроки поставки под заказ (от 5 рабочих дней);
- Экспресс доставка в любую точку России;
- Техническая поддержка проекта, помощь в подборе аналогов, поставка прототипов;
- Система менеджмента качества сертифицирована по Международному стандарту ISO 9001;
- Лицензия ФСБ на осуществление работ с использованием сведений, составляющих государственную тайну;
- Поставка специализированных компонентов (Xilinx, Altera, Analog Devices, Intersil, Interpoint, Microsemi, Aeroflex, Peregrine, Syfer, Eurofarad, Texas Instrument, Miteq, Cobham, E2V, MA-COM, Hittite, Mini-Circuits, General Dynamics и др.);

Помимо этого, одним из направлений компании «ЭлектроПласт» является направление «Источники питания». Мы предлагаем Вам помощь Конструкторского отдела:

- Подбор оптимального решения, техническое обоснование при выборе компонента;
- Подбор аналогов;
- Консультации по применению компонента;
- Поставка образцов и прототипов;
- Техническая поддержка проекта;
- Защита от снятия компонента с производства.



Как с нами связаться

Телефон: 8 (812) 309 58 32 (многоканальный)

Факс: 8 (812) 320-02-42

Электронная почта: org@eplast1.ru

Адрес: 198099, г. Санкт-Петербург, ул. Калинина, дом 2, корпус 4, литера А.