

Surface Mount PTC

OZCF Series

HF **Pb** OZCF Series -2920 Chip

RoHS 6 Compliant & Halogen-Free

Application

All high-density boards

Product Features

2920 Chip Size , Fast Trip Time, High Hold Currents

Operating (Hold Current) Range

300mA - 3A

Maximum Voltage

6 - 60V (per table)

Temperature Range

-40°C to 85°C

Agency Approval

TUV (Std. EN60738-1-1, Cert. R50102117)

UL Component (Std. UL1434, File E305051)

UL Conditions of Acceptability:

1. These devices have been investigated for use in safety circuits and are suitable as a limiting device.
2. These devices have been calibrated to limit the current to 8 amps within 5 seconds, per ANSI/NFPA 70, "National Electrical Code".

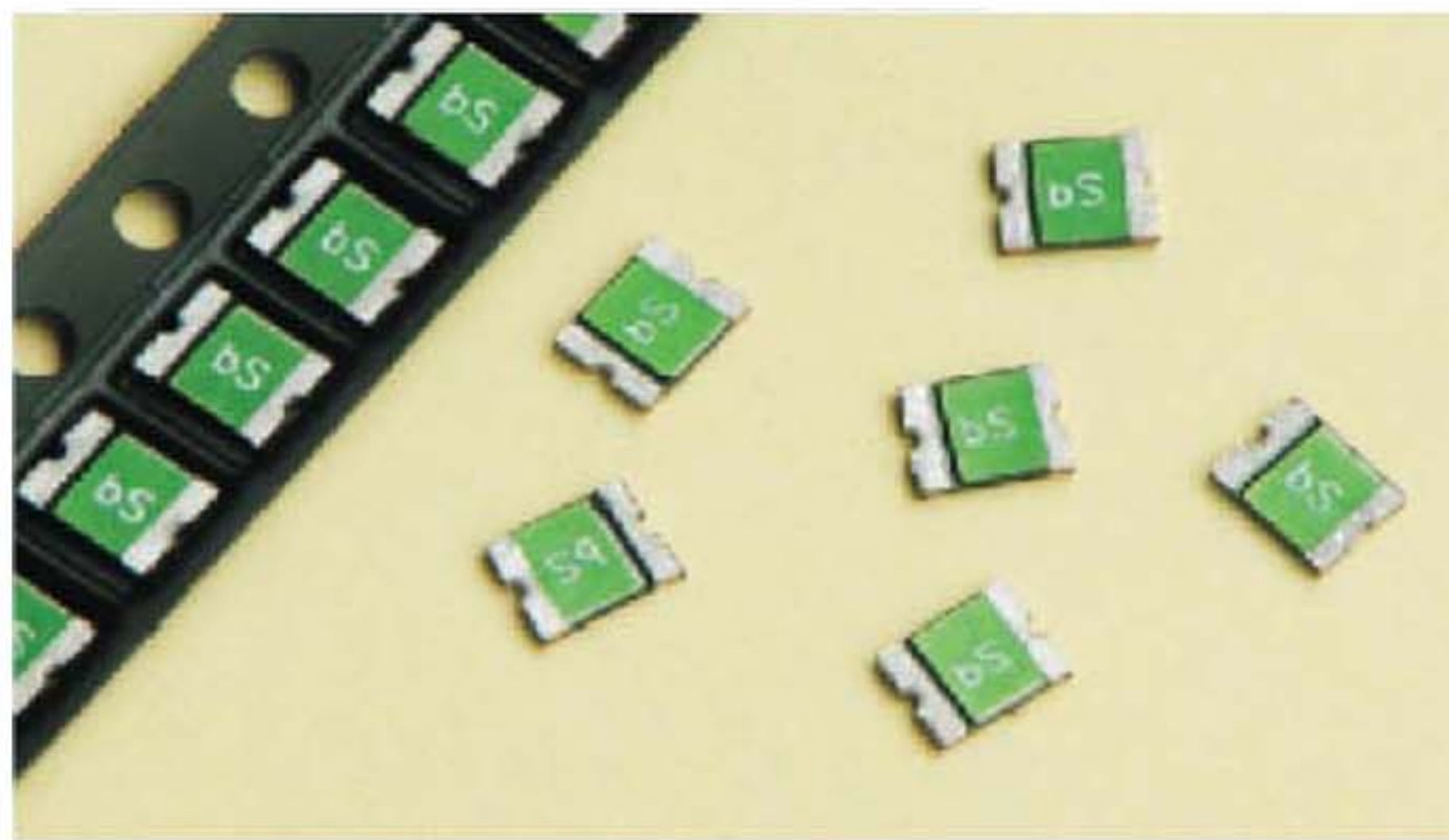

LEAD FREE = **Pb**

HALOGEN FREE = **HF**

Electrical Characteristics (23°C)

	Part Number	Hold Current IH, A	Trip Current IT, A	Rated Voltage Vmax, Vdc	Maximum Current Imax, A	Typical Power Pd, W	Max Time to Trip		Resistance Tolerance		Agency Approvals	
							Current A	Time Sec	Rmin Ohms	R1max Ohms	UL US	TUV
A	OZCF0030FF2C	0.30	0.60	60	100	1.5	1.5	3.0	1.000	4.800	Y	Y
B	OZCF0050FF2C	0.50	1.00	60	100	1.5	2.5	4.0	0.300	1.400	Y	Y
C	OZCF0075FF2C	0.75	1.50	33	100	1.5	8.0	0.3	0.180	1.000	Y	Y
	OZCF0075AF2C	0.75	1.50	60	100	1.5	8.0	0.3	0.180	1.000	Y	Y
D	OZCF0110FF2C	1.10	2.20	33	100	1.5	8.0	0.5	0.090	0.410	Y	Y
E	OZCF0125FF2C	1.25	2.50	33	100	1.5	8.0	2.0	0.050	0.250	Y	Y
F	OZCF0150FF2C	1.50	3.00	33	100	1.5	8.0	2.0	0.050	0.230	Y	Y
G	OZCF0185FF2C	1.85	3.70	33	100	1.5	8.0	2.5	0.040	0.150	Y	Y
H	OZCF0200FF2C	2.00	4.00	16	100	1.5	8.0	4.5	0.035	0.120	Y	Y
	OZCF0200AF2C	2.00	4.00	24	100	1.5	8.0	5.0	0.035	0.120	Y	Y
I	OZCF0250FF2C	2.50	5.00	16	100	1.5	8.0	16.0	0.025	0.085	Y	Y
J	OZCF0260FF2C	2.60	5.20	6	100	1.5	8.0	20.0	0.020	0.075	Y	Y
K	OZCF0300FF2C	3.00	5.20	6	100	1.5	8.0	25.0	0.010	0.048	Y	Y
	OZCF0300AF2C	3.00	5.20	15	100	1.5	8.0	25.0	0.010	0.048	Y	Y

IH Hold Current-maximum current at which the device will not trip in still air at 23°C.

IT Trip current-minimum current at which the device will always trip in still air at 23°C.

Imax Maximum fault current device can withstand without damage at rated voltage (Vmax).

Vmax Maximum voltage device can withstand without damage at its rated current.

Pd Typical power dissipated by device when in tripped state in 23°C still air environment.

Rmin Minimum device resistance at 23°C.

R1max Maximum device resistance at 23°C, 1 hour after initial device trip, or after being soldered to PCB in end application.

Specifications subject to change without notice



Bel Fuse Inc.
206 Van Vorst Street
Jersey City, NJ 07302 USA

+1 201.432.0463
techhelp@belf.com
belfuse.com

Surface Mount PTC

OZCF Series

HF Pb OZCF Series -2920 Chip

RoHS 6 Compliant & Halogen-Free

PTC's - Basic Theory of Operation / "Tripped" Resistance Explanation

Fundamentally, a Bel PTC consists of a block of polymeric material containing conductive filler and bonded between two conductive, planar terminations.

At currents below the device I_{HOLD} rating, AND at temperatures below 100C, the PTC maintains a resistance value below its R_{1 MAX} rating.

As the device's temperature approaches 130C, either due to an increase in ambient temperature or a current exceeding its I_{TRIP} rating, volumetric expansion of the filled polymer breaks apart the majority of conductive pathways across the terminals created by chain contact of adjacent filler particles or device resistance increases sharply by several orders of magnitude.

At the much higher "Tripped" resistance, there is just enough leakage current to allow internal heating to "hold" the device in its tripped state (around 125C) until power is interrupted. Once power is removed, the PTC's core cools and contracts allowing conductive chains to reform and return the device to its low resistance state.

The catalog data for each device specifies a "Typical Power" value. This is the power required to exactly match the heat lost by the tripped device to its ambient surroundings at 23C. By Ohm's Law, power can be stated as: $W = E^2/R$. Thus the approximate resistance of a "Tripped" PTC can be determined by: $R = E^2/W$, where "E" is the voltage appearing across the PTC (usually the supply's open circuit voltage), and "W" is the Typical Power value for the particular PTC. Since the PPTC acts to maintain a constant internal temperature, its apparent resistance will change based upon applied voltage and, to a lesser degree, ambient conditions. Consider the following example....

A PTC with a Typical Power of 1 watt protecting a circuit using a 60V supply will demonstrate an apparent, tripped resistance "R" of:

$$R = 60^2/1 = 3,600 \text{ ohms}$$

This same tripped device when used to protect a 12V circuit would now present an apparent resistance of:

$$R = 12^2/1 = 144 \text{ ohms}$$

The value for Typical Power is "typical" because any physical factors that affect heat loss (such as ambient temperature or air convection) will somewhat alter the level of power that the PTC needs to maintain its internal temperature. In short, PTCs do not exhibit a constant, quantifiable tripped resistance value.

Type Time - To - Trip at 23°C

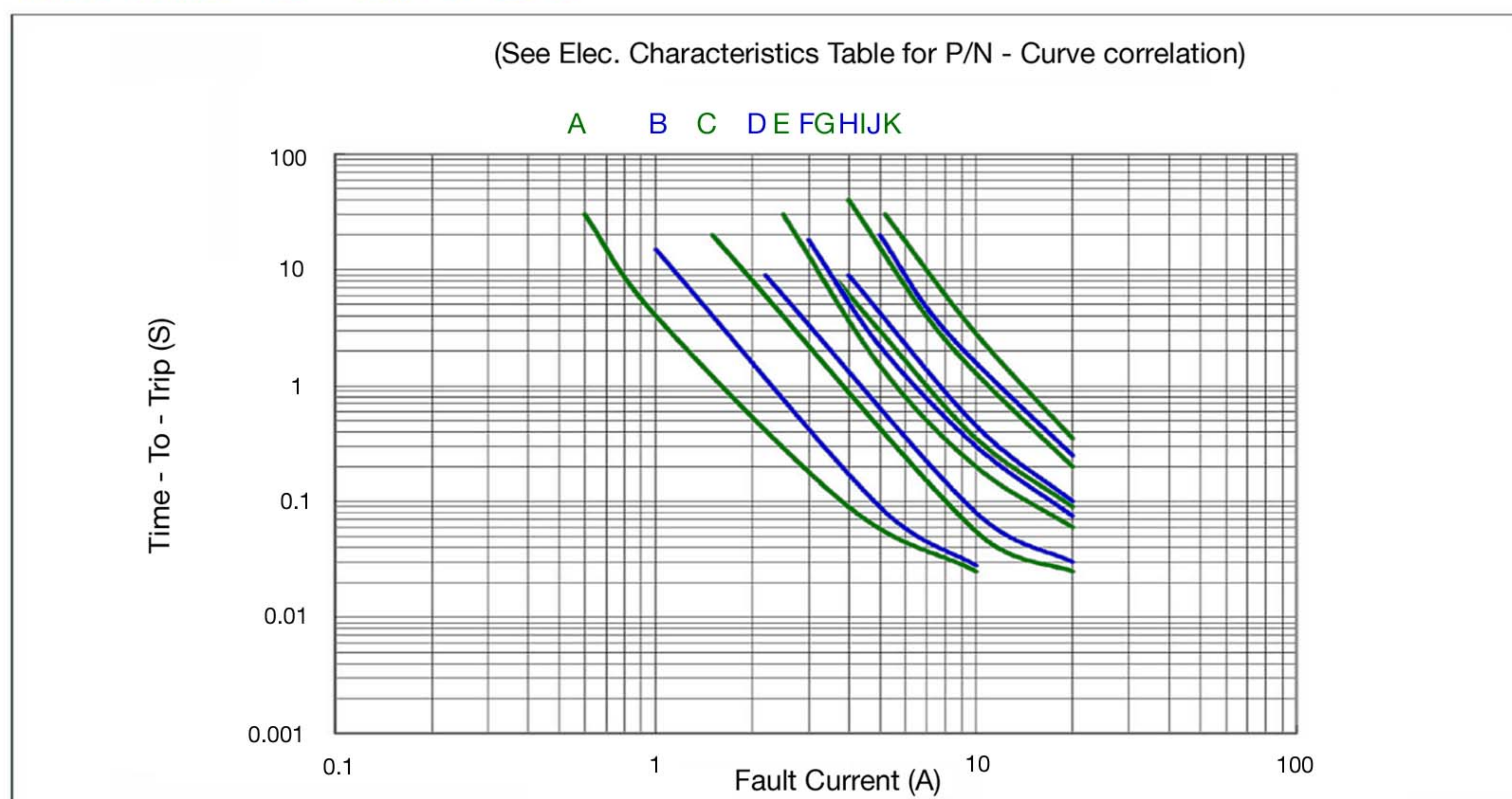

Specifications subject to change without notice



Bel Fuse Inc.
206 Van Vorst Street
Jersey City, NJ 07302 USA

+1 201.432.0463
techhelp@belf.com
belfuse.com

Surface Mount PTC

OZCF Series

HF  OZCF Series -2920 Chip

RoHS 6 Compliant & Halogen-Free

Pad Layout

The dimensions in the table below provide the recommended pad layout.

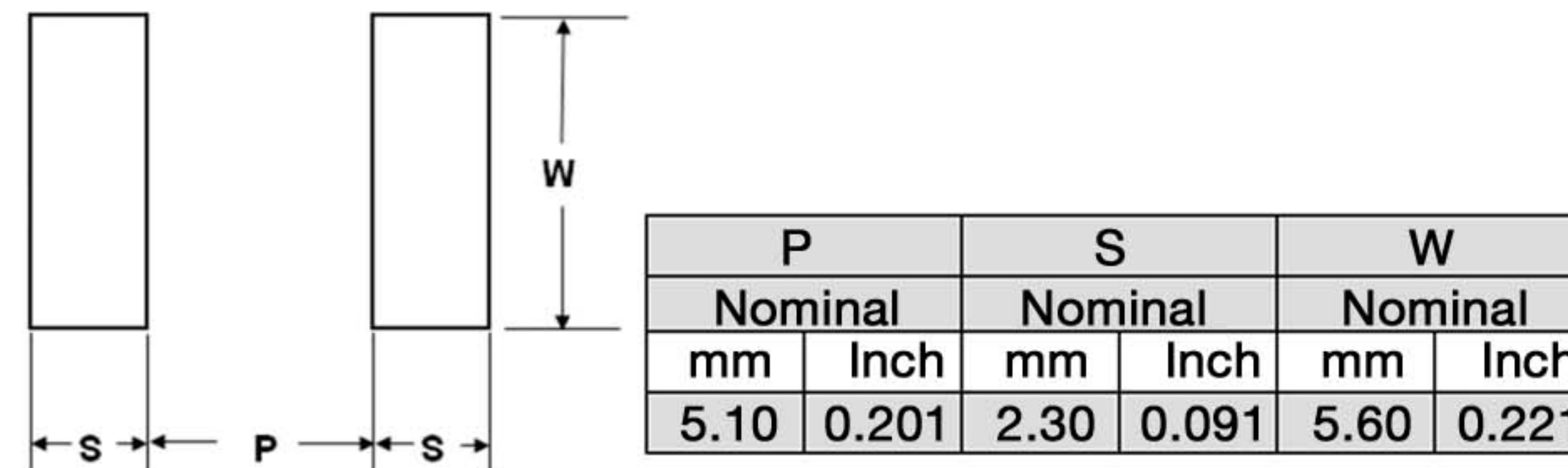

Termination Pad Materials

Matte Tin - Plated Copper

Mechanical Dimensions and Marking

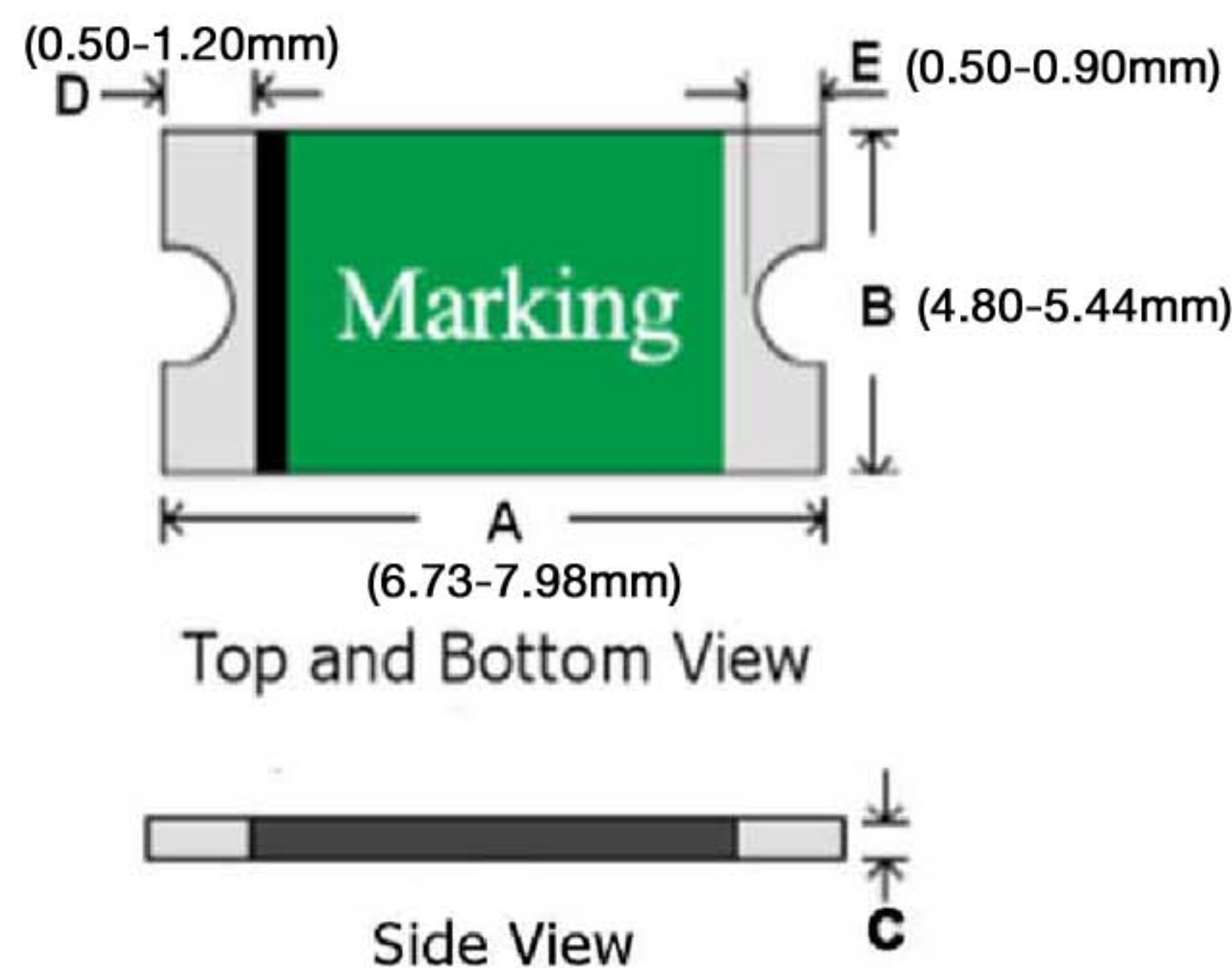

All dimensions in mm.

Part Number	Dimensions		Marking Code	
	Min	Max	"b", IH code.	
0ZCF0030FF2C	0.60	1.15	0030	
0ZCF0050FF2C	0.60	1.15	0050	
0ZCF0075FF2C	0.40	1.15	0075	
0ZCF0075AF2C	0.60	1.15		0075 60
0ZCF0110FF2C	0.40	1.00	0110	
0ZCF0125FF2C	0.40	0.90	0125	
0ZCF0150FF2C	0.40	0.90	0150	
0ZCF0185FF2C	0.30	0.90	0185	
0ZCF0200FF2C	0.30	0.90	0200	
0ZCF0200AF2C	0.20	0.80		0200 24
0ZCF0250FF2C	0.30	0.90	0250	
0ZCF0260FF2C	0.30	0.90	0260	
0ZCF0300FF2C	0.40	0.90	0300	
0ZCF0300AF2C	0.65	1.15		0300 15

Thermal Derating Curve

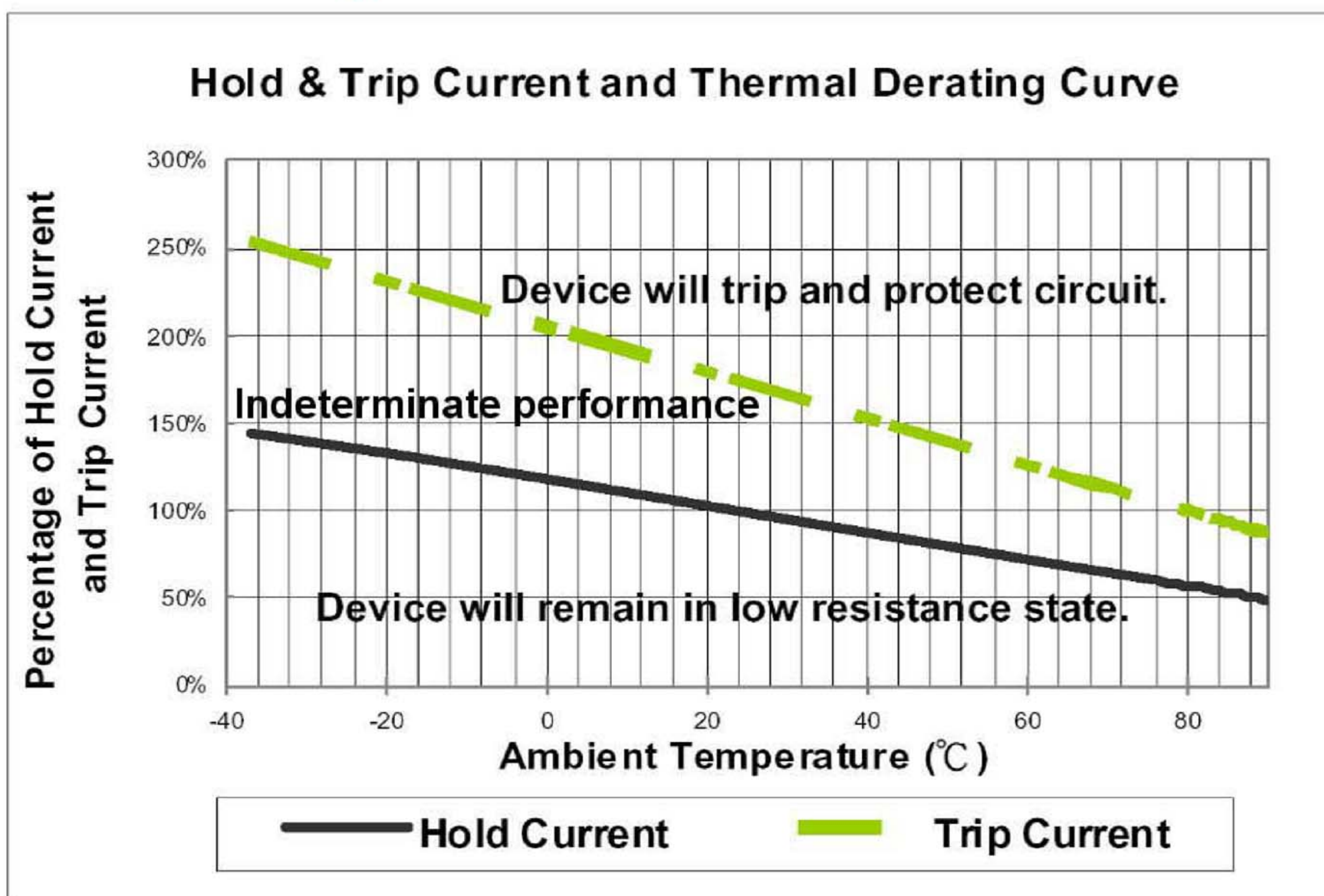

Cautionary Notes

1. Operation beyond the specified maximum ratings or improper use may result in damage and possible electrical arcing and/or flame.
2. These Polymer PTC (PPTC) devices are intended for protection against occasional overcurrent/ overtemperature fault conditions and may not be suitable for use in applications where repeated and/or prolonged fault conditions are anticipated.
3. Avoid contact of PTC device with chemical solvent. Prolonged contact may adversely impact the PTC performance.
4. These PTC devices may not be suitable for use in circuits with a large inductance, as the PTC trip can generate circuit voltage spikes above the PTC rated voltage.
5. These devices are intended for use in DC voltage applications only. Use in AC voltage applications should be first discussed with Bel Fuse engineering.
6. Not recommended for use on potted or conformal coated PCB's. Restriction of free air flow could affect electrical performance and/or result in device failure. Consult Bel Fuse engineering.
7. In the "Indeterminate Performance / grey zone", tripping may occur but cannot be relied upon. For special circumstances considering use within this region, consult Bel Fuse Engineering.
8. MSL : 2a (According to IPC J-Std-020).

Specifications subject to change without notice



Bel Fuse Inc.
206 Van Vorst Street
Jersey City, NJ 07302 USA

+1 201.432.0463
techhelp@belf.com
belfuse.com

Surface Mount PTC

OZCF Series

HF  OZCF Series -2920 Chip

RoHS 6 Compliant & Halogen-Free

Solder Reflow and Rework Recommendations

Profile Feature	Pb-Free Assembly
Average Ramp-Up Rate (T _{smax} to T _p)	3°C/second max
Preheat :	
Temperature Min (T _{smin})	150°C
Temperature Max (T _{smax})	200°C
Time (t _{smin} to t _{smax})	60-180 seconds
Time maintained above:	
Temperature(T _L)	217°C
Time (t _L)	60-150 seconds
Peak/Classification Temperature(T _p) :	260°C
Time within 5°C of actual Peak :	
Temperature (t _p)	20-40 seconds
Ramp-Down Rate :	6°C/second max.
Time 25°C to Peak Temperature :	8 minutes max

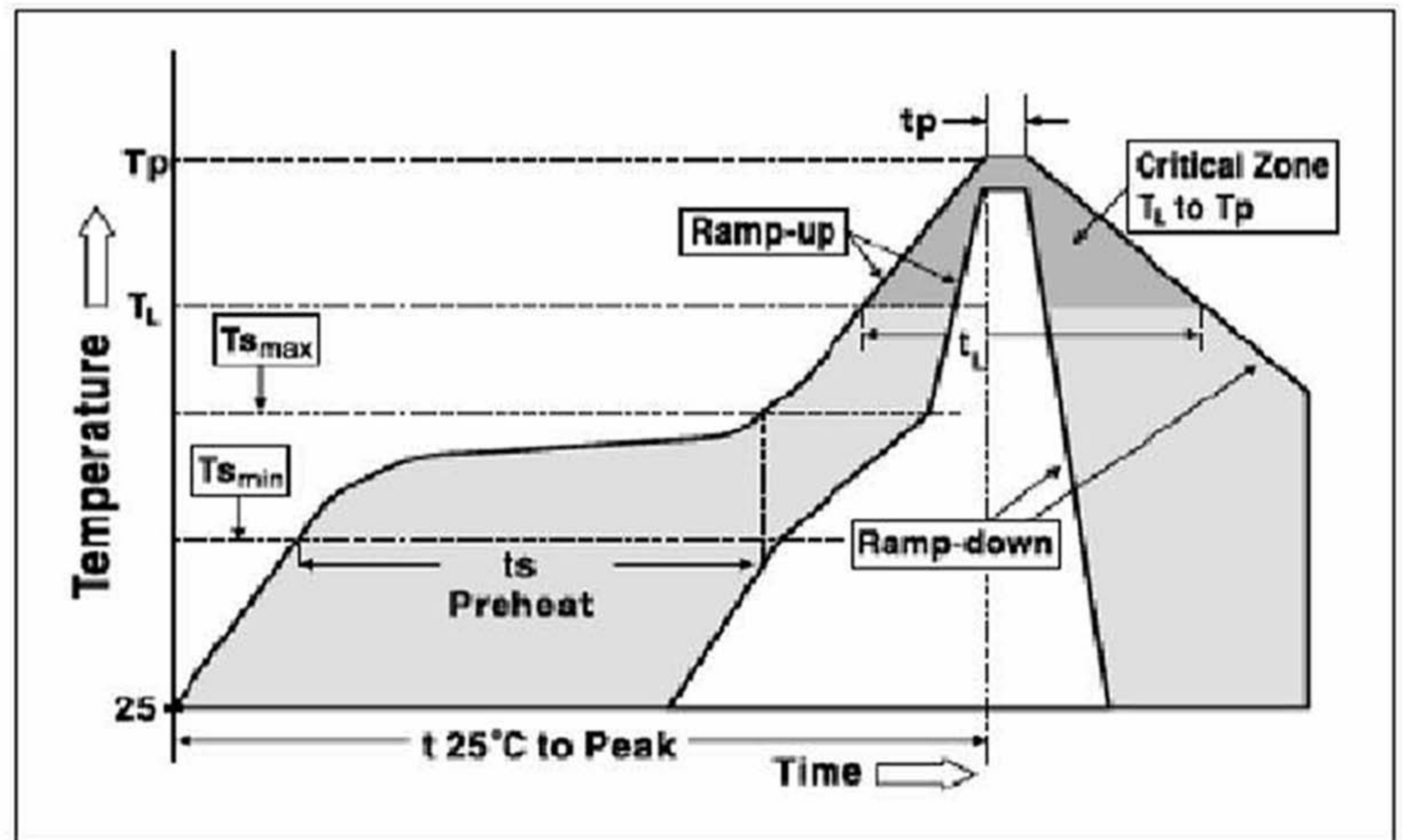

Solder Reflow

Due to "lead free / RoHS 6" construction of these PTC devices, the required Temperature and Dwell Time in the "Soldering" zone of the reflow profile are greater than those used for non-RoHS devices.

1. Recommended reflow methods ; IR, vapor phase oven, hot air oven.
2. Not Recommended For Wave Solder / Direct Immersion.
3. Recommended maximum paste thickness is 0.25mm.
4. Devices are compatible with standard industry cleaning solvents and methods.
5. MSL : 2a (According to IPC J-Std-020).

Caution

If reflow temperature / dwell times exceed the recommended profile, the electrical performance of the PTC may be affected.

Rework : MIL-STD-202G Method 210F, Test Condition A.

Standard Packaging

Part Number	Tape/Reel Qty	2000 fuses in 7 inches dia. Reel, 8mm wide tape, 4mm pitch, per EIA-481(equivalent IEC-286 part 3).
OZCF0030FF2C	2,000	
OZCF0050FF2C		
OZCF0075FF2C		
OZCF0075AF2C		
OZCF0110FF2C		
OZCF0125FF2C		
OZCF0150FF2C		
OZCF0185FF2C		
OZCF0200FF2C		
OZCF0200AF2C		
OZCF0250FF2C		
OZCF0260FF2C		
OZCF0300FF2C		
OZCF0300AF2C		

P/N Explanation and Ordering Information

	OZCF	OXXX	X	X	XX
PTC series	OZCF, 2920 Size				
I HOLD Rating	Refer to Part Number and IH Rating in Electrical Characteristics Table on P.1.				
Electrical Characteristics	F = Standard Design A to Z (except F) = Special, customer spec, DCR sort, etc.				
Mechanical Features	F = Standard Design A to Z (except F) = Special, customer spec, lead forming, etc.				
Tape & Reel Qty	See standard packaging				

Specifications subject to change without notice



Bel Fuse Inc.
206 Van Vorst Street
Jersey City, NJ 07302 USA

+1 201.432.0463
techhelp@belf.com
belfuse.com



Компания «ЭлектроПласт» предлагает заключение долгосрочных отношений при поставках импортных электронных компонентов на взаимовыгодных условиях!

Наши преимущества:

- Оперативные поставки широкого спектра электронных компонентов отечественного и импортного производства напрямую от производителей и с крупнейших мировых складов;
- Поставка более 17-ти миллионов наименований электронных компонентов;
- Поставка сложных, дефицитных, либо снятых с производства позиций;
- Оперативные сроки поставки под заказ (от 5 рабочих дней);
- Экспресс доставка в любую точку России;
- Техническая поддержка проекта, помощь в подборе аналогов, поставка прототипов;
- Система менеджмента качества сертифицирована по Международному стандарту ISO 9001;
- Лицензия ФСБ на осуществление работ с использованием сведений, составляющих государственную тайну;
- Поставка специализированных компонентов (Xilinx, Altera, Analog Devices, Intersil, Interpoint, Microsemi, Aeroflex, Peregrine, Syfer, Eurofarad, Texas Instrument, Miteq, Cobham, E2V, MA-COM, Hittite, Mini-Circuits, General Dynamics и др.);

Помимо этого, одним из направлений компании «ЭлектроПласт» является направление «Источники питания». Мы предлагаем Вам помощь Конструкторского отдела:

- Подбор оптимального решения, техническое обоснование при выборе компонента;
- Подбор аналогов;
- Консультации по применению компонента;
- Поставка образцов и прототипов;
- Техническая поддержка проекта;
- Защита от снятия компонента с производства.



Как с нами связаться

Телефон: 8 (812) 309 58 32 (многоканальный)

Факс: 8 (812) 320-02-42

Электронная почта: org@eplast1.ru

Адрес: 198099, г. Санкт-Петербург, ул. Калинина, дом 2, корпус 4, литера А.